

CMT SHEET NAME	REF AREA
/sys/cmt_if/prod_test_pattern	2060-2069
/sys/cmt_if/battery_conn	2070-2099
/sys/cmt_if/audio	2000-2029
/sys/cmt_if/audio	2100-2199
/sys/cmt_if/itu	2400-2499
/sys/cmt_if/camera	2500-2599
/sys/cmt_if/sim	2700-2799
/sys/cmt_if/emu_rap	3100-3120
/sys/cmt_if/wing	4000-4099
/sys/cmt_if/lid	3800-3899
/sys/cmt_if/bt	6000-6099
/sys/cmt_if/wlan	6300-6510
/sys/cmt_if/conn/charger-USB	2030-2039

CMT SHEET NAME	REF AREA
/sys/cmt_engine/power/vilma	2200-2299
/sys/cmt_engine/power/betty	2300-2389
/sys/cmt_engine/power/coreps	2390-2399
/sys/cmt_engine/digi/rapido	2800-2849
/sys/cmt_engine/digi/geniomux	2850-2899
/sys/cmt_engine/digi/mem_cmt/combo	3000-3099
/sys/cmt_engine/digi/mem_cmt/sd_card	3200-3299

RF SHEET NAME	REF AREA
/RF	7500-7599
/MUTANT	8000-8010

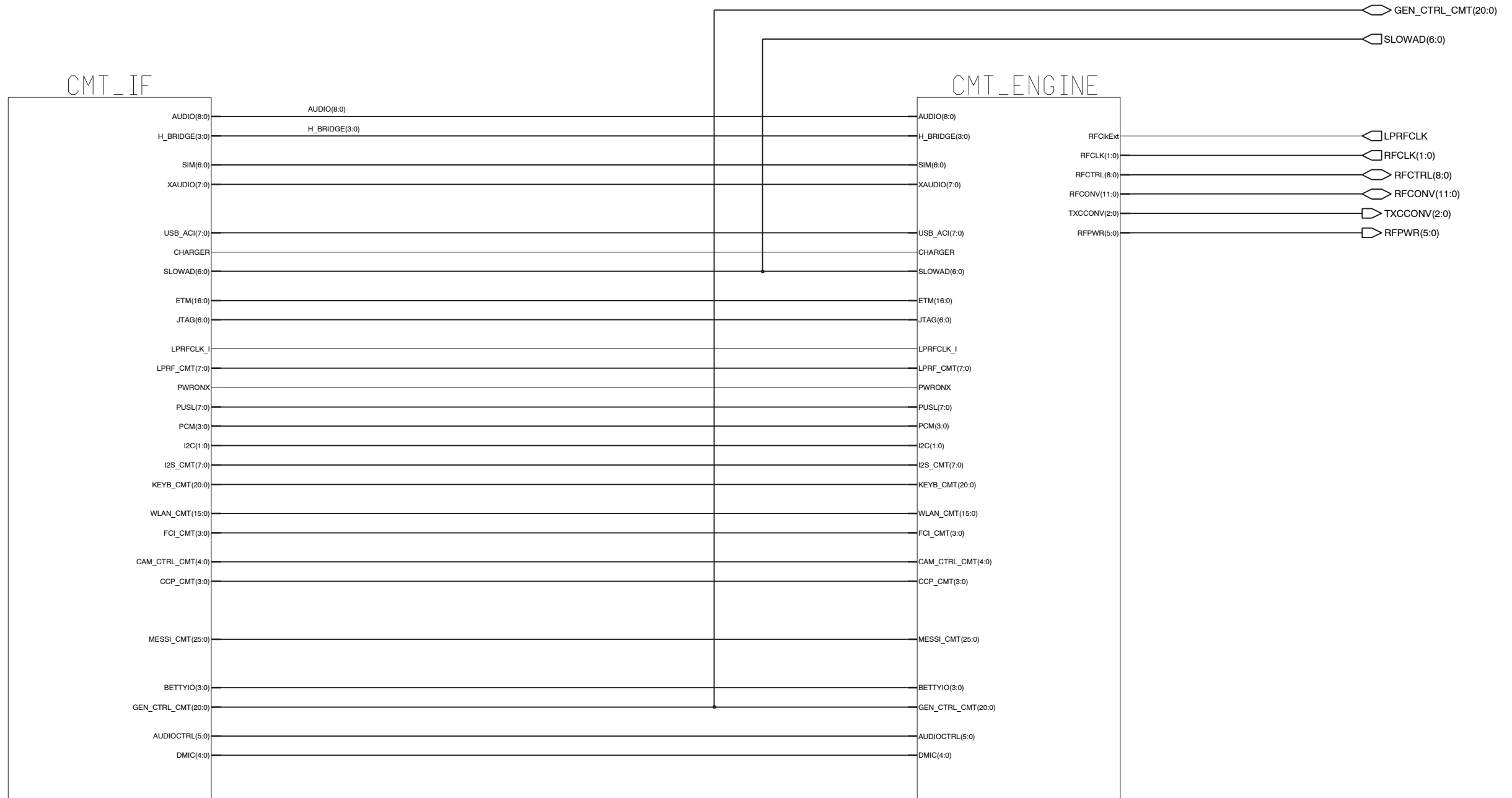

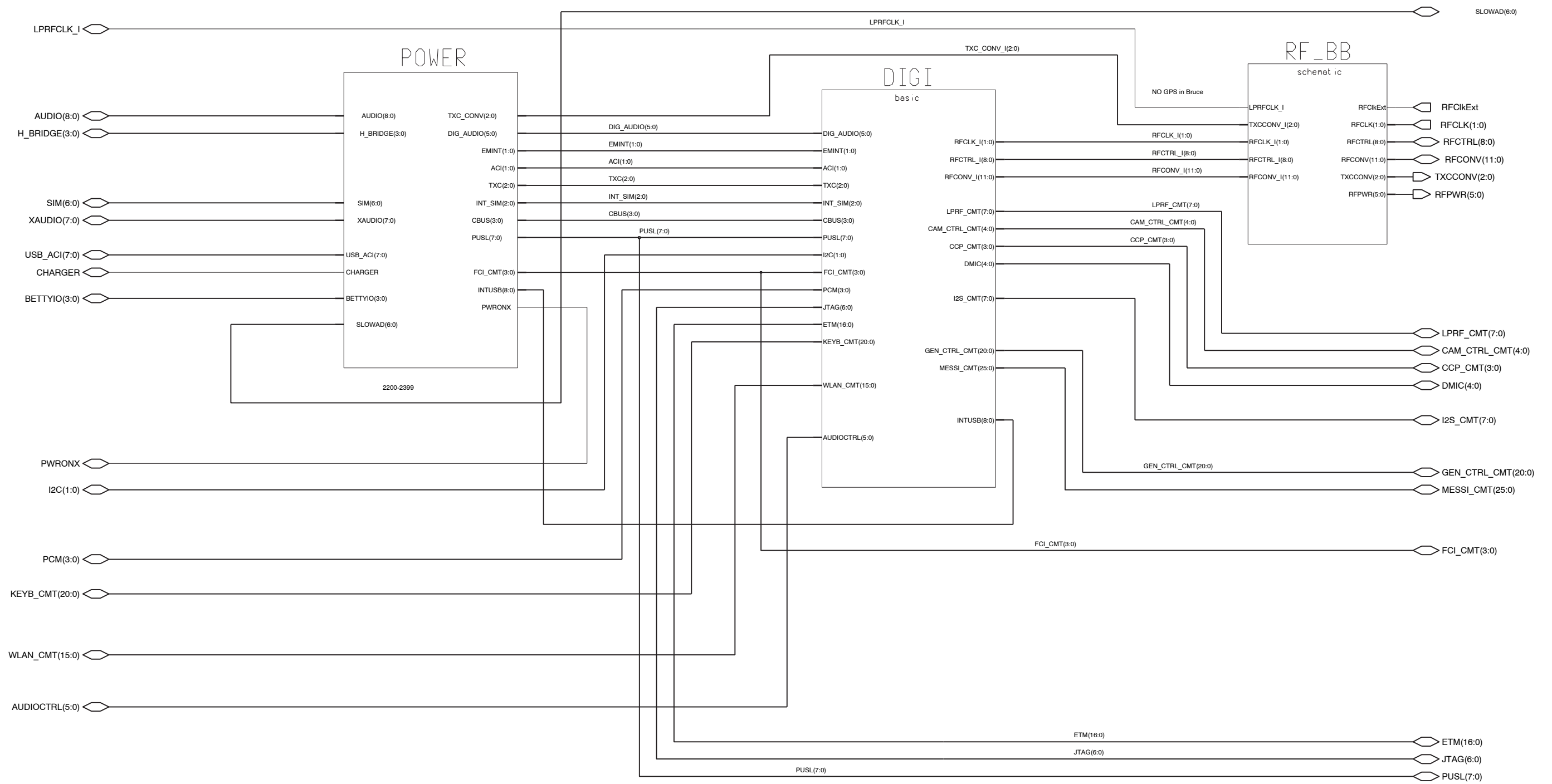

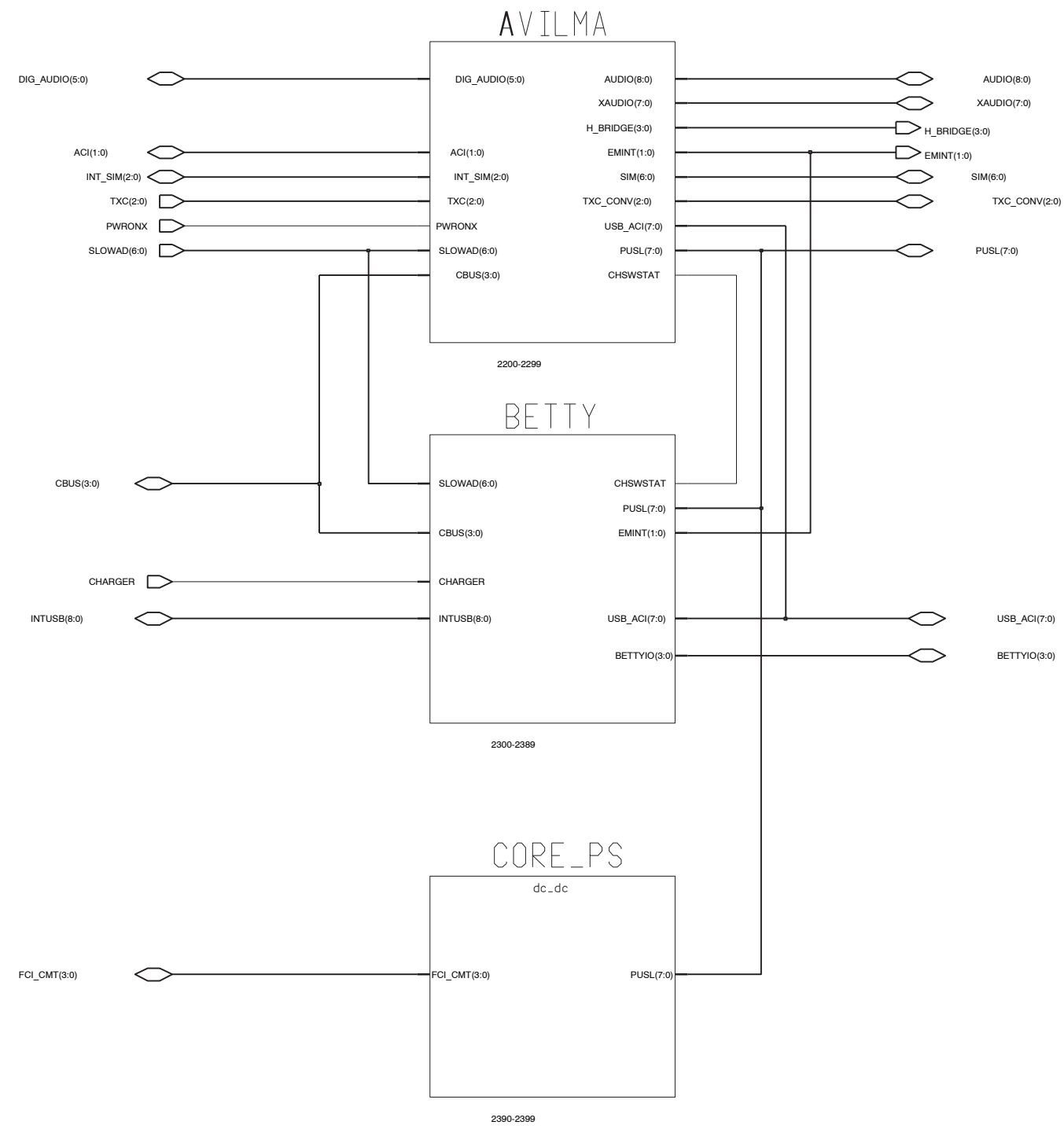

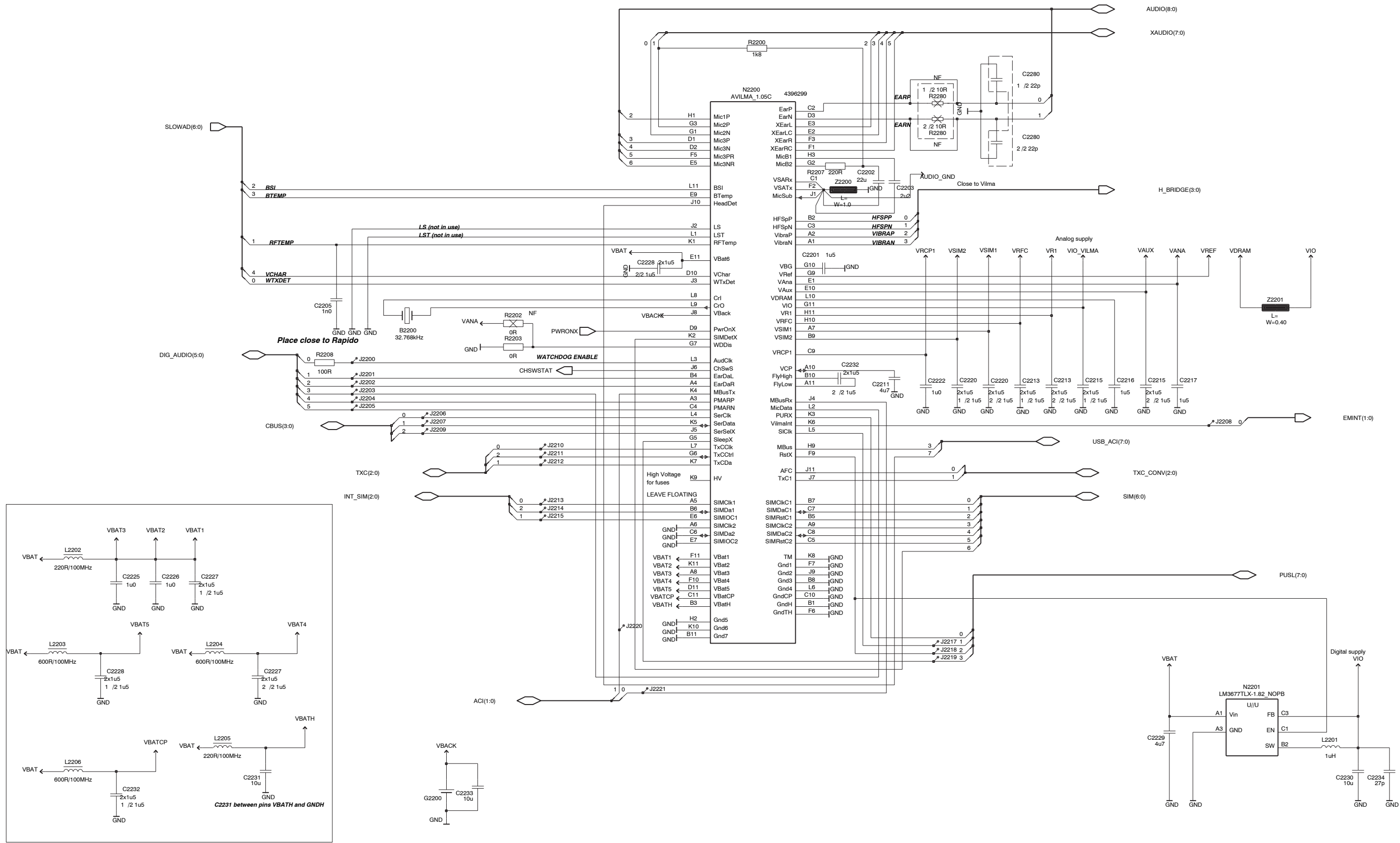

SLOWAD(6:0)

2 BSI
3 BTEMP
1 RETEMP
4 VCHAR
0 WTXDET

DIG_AUDIO(5:0)

Place close to Rapido

CBUS(3:0)

TXC(2:0)

INT_SIM(2:0)

ACI(1:0)

0 1
2 3 4 5
6

H1 Mic1P
G3 Mic2P
G1 Mic2N
D1 Mic3P
D2 Mic3N
F5 Mic3PR
E5 Mic3NR

L11 BSI
E9 BTemp
J10 HeadDet

J2 LS
L1 LST
K1 RFTemp

E11 VBat6
D10 VChar
J3 WTXDet

L8 CrI
L9 CrO
J8 VBack

D9 PwrOnX
K2 SIMDetX
G7 WDDis

L3 AudCk
J6 ChSwS
B4 EarDaL
A4 EarDaR

K4 MBusTx
A3 PMARP
C4 PMARN
L4 SerCk
K5 SerData
J5 SerSelX

G5 SleepX
L7 TxCCk
G6 TxCCtrl
K7 TxCDa

K9 HV
A5 LEAVE FLOATING
B6 SIMCk1
E6 SIMDa1
E6 SIMIOC1

GND A6 SIMCk2
GND C6 SIMDa2
GND E7 SIMIOC2

F11 VBat1
K11 VBat2
A8 VBat3
F10 VBat4
D11 VBat5
C11 VBatCP
B3 VBatH

GND H2 Gnd5
GND K10 Gnd6
GND B11 Gnd7

J2220

1 0 J2221

J2222

J2223

J2224

J2225

J2226

J2227

J2228

J2229

J2230

J2231

J2232

J2233

J2234

J2235

J2236

J2237

J2238

J2239

J2240

J2241

J2242

J2243

J2244

J2245

J2246

J2247

J2248

J2249

J2250

J2251

J2252

J2253

J2254

J2255

J2256

J2257

J2258

J2259

J2260

J2261

J2262

J2263

J2264

J2265

J2266

J2267

J2268

J2269

J2270

J2271

J2272

J2273

J2274

J2275

J2276

J2277

J2278

J2279

J2280

J2281

J2282

J2283

J2284

J2285

J2286

J2287

J2288

J2289

J2290

J2291

J2292

J2293

J2294

J2295

J2296

J2297

J2298

J2299

J2300

J2301

J2302

J2303

J2304

J2305

J2306

J2307

J2308

J2309

J2310

J2311

J2312

J2313

J2314

J2315

J2316

J2317

J2318

J2319

J2320

J2321

J2322

J2323

J2324

J2325

J2326

J2327

J2328

J2329

J2330

J2331

J2332

J2333

J2334

J2335

J2336

J2337

J2338

J2339

J2340

J2341

J2342

J2343

J2344

J2345

J2346

J2347

J2348

J2349

J2350

J2351

J2352

J2353

J2354

J2355

J2356

J2357

J2358

J2359

J2360

J2361

J2362

J2363

J2364

J2365

J2366

J2367

J2368

J2369

J2370

J2371

J2372

J2373

J2374

J2375

J2376

J2377

J2378

J2379

J2380

J2381

J2382

J2383

J2384

J2385

J2386

J2387

J2388

J2389

J2390

J2391

J2392

J2393

J2394

J2395

J2396

J2397

J2398

J2399

J2400

J2401

J2402

J2403

J2404

J2405

J2406

J2407

J2408

J2409

J2410

J2411

J2412

J2413

J2414

J2415

J2416

J2417

J2418

J2419

J2420

J2421

J2422

J2423

J2424

J2425

J2426

J2427

J2428

J2429

J2430

J2431

J2432

J2433

J2434

J2435

J2436

J2437

J2438

J2439

J2440

J2441

J2442

J2443

J2444

J2445

J2446

J2447

J2448

J2449

J2450

AUDIO(8:0)

XAUDIO(7:0)

H_BRIDGE(3:0)

EMINT(1:0)

USB_ACI(7:0)

TXC_CONV(2:0)

SIM(6:0)

PUSL(7:0)

Digital supply

VIO

VREF

VANA

VAUX

VIO_VILMA

VR1

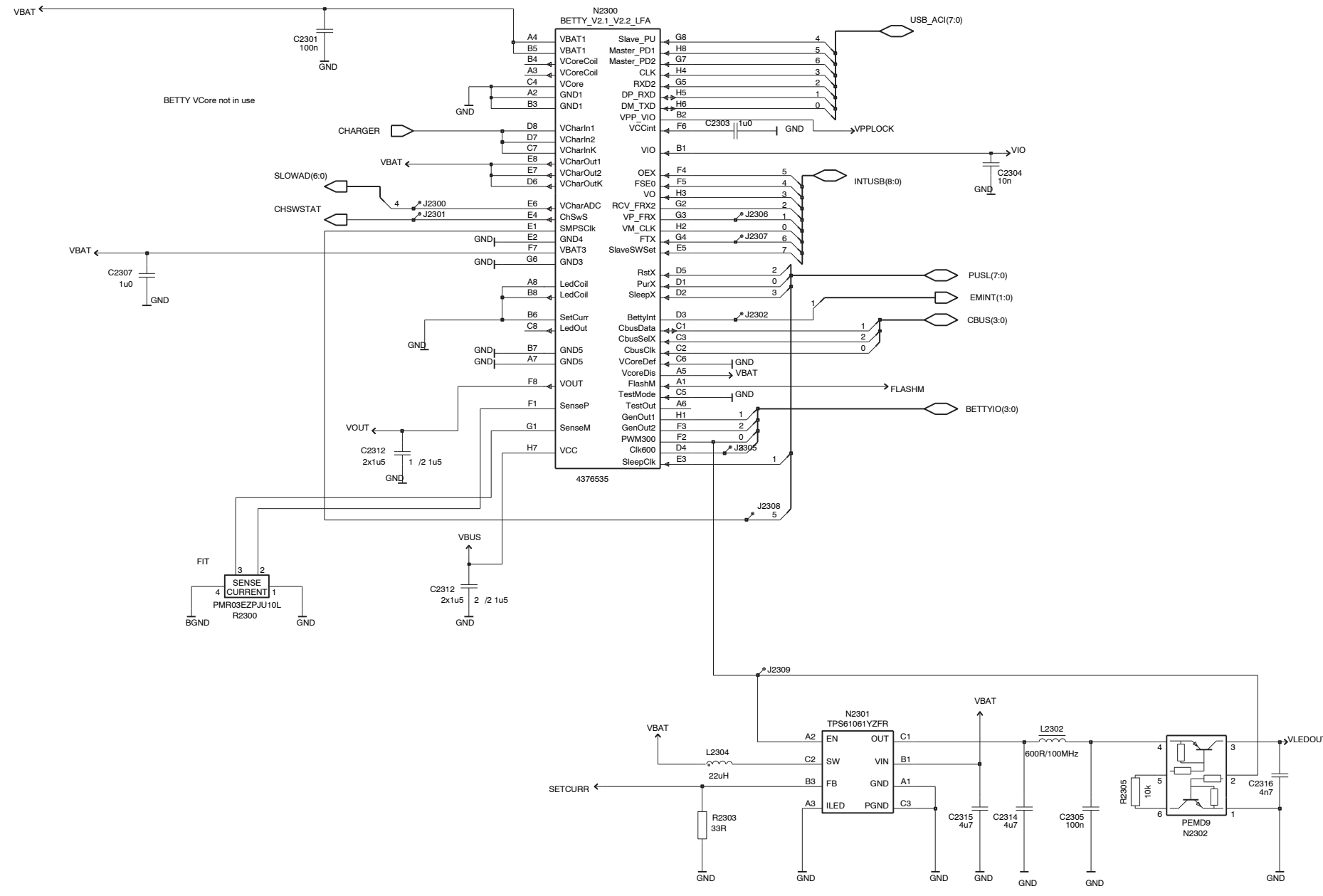

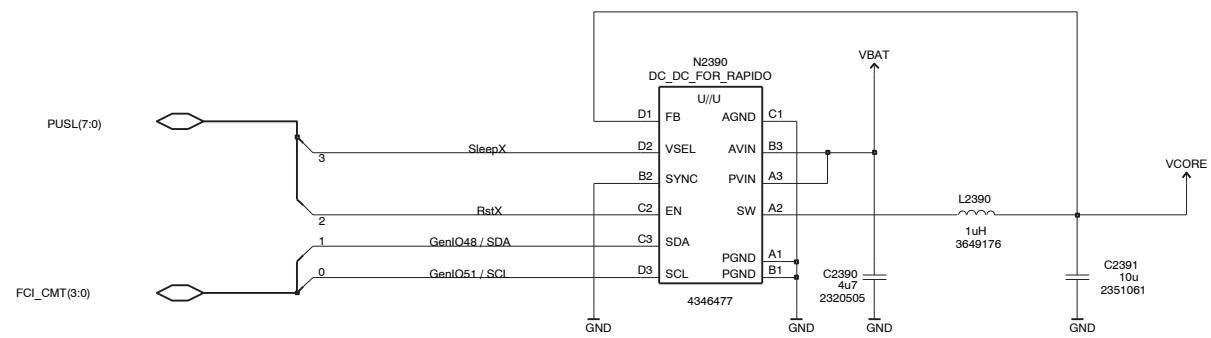

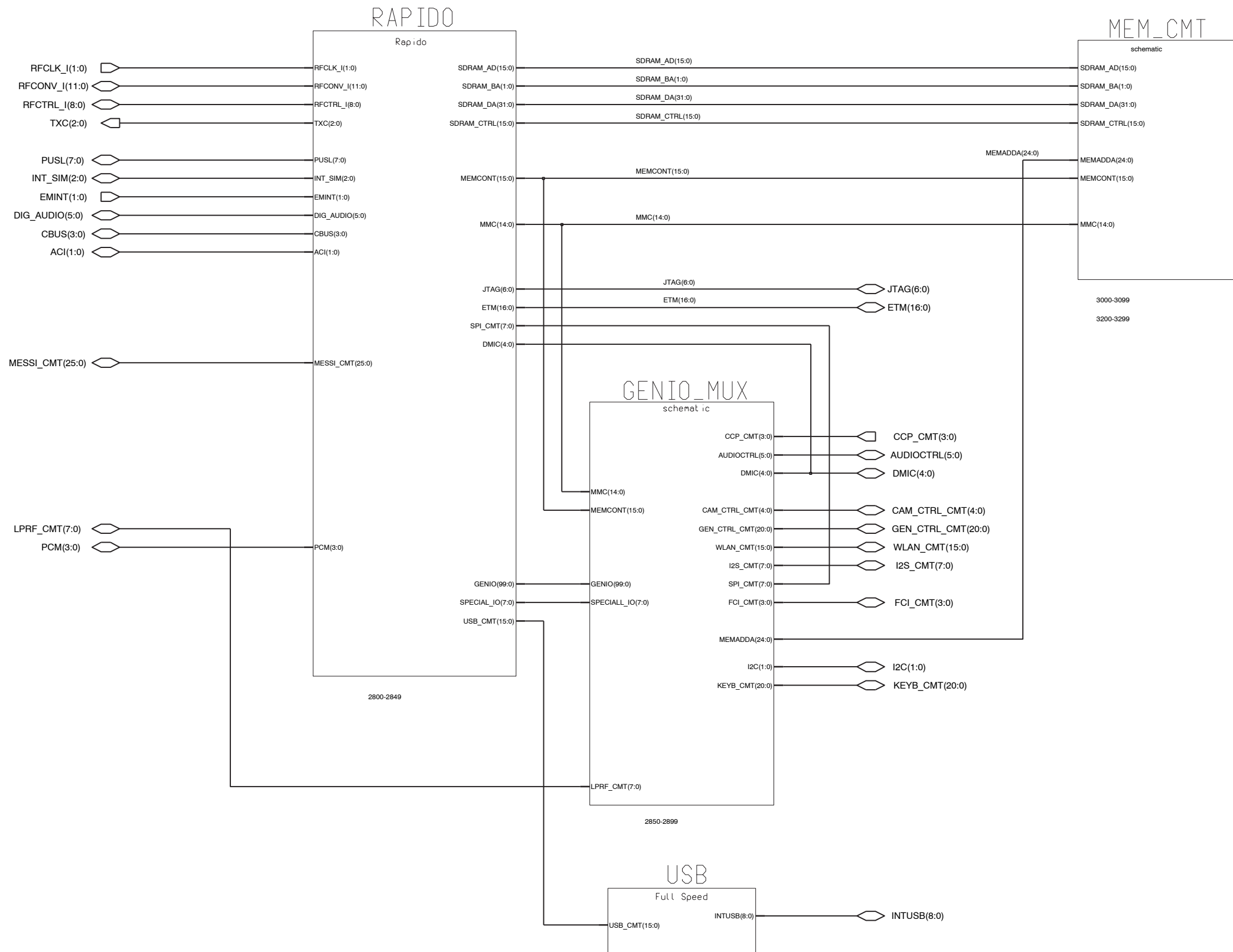

0	genio0	MEMADDA0
1	genio1	MEMADDA1
2	genio2	MEMADDA2
3	genio3	MEMADDA3
4	genio4	MEMADDA4
5	genio5	MEMADDA5
6	genio6	MEMADDA6
7	genio7	MEMADDA7
8	genio8	MEMADDA8
9	genio9	MEMADDA9
10	genio10	MEMADDA10
11	genio11	MEMADDA11
12	genio12	MEMADDA12
13	genio13	MEMADDA13
14	genio14	MEMADDA14
15	genio15	MEMADDA15
16	genio16	IHF_PA_EN
17	genio17	SIGN_PLUG_DET
18	genio18	SIGN_PA_EN
19	genio19	SIGN_DATA_CTRL
20	genio20	FM_INT
21	genio21	BT_WAKEUP
22	genio22	FLASH_INT
23	genio23	KEYB_COLUMN_0
24	genio24	ANT_ST1
25	genio25	ANT_ST2
26	genio26	KEYB_COLUMN_1
27	genio27	CAM_HWA_LDO_STB
28	genio28	AIC33_RESETX
29	genio29	WLAN_IRQ
30	genio30	I2C_SYMB_SDA
31	genio31	I2C_SYMB_SCL
32	genio32	KEYB_ROW_0
33	genio33	KEYB_ROW_1
34	genio34	KEYB_ROW_2
35	genio35	KEYB_ROW_3
36	genio36	KEYB_ROW_4
37	genio37	KEYB_ROW_5
38	genio38	KEYB_ROW_6
39	genio39	KEYB_ROW_7
40	genio40	NAVISCROLL_INT
41	genio41	KEYB_COLUMN_2
42	genio42	DIG_MIC_AUXTPDM
43	genio43	KEYB_COLUMN_3
44	genio44	LCD_RSTX
45	genio45	SD_PREWARNING
46	genio46	MMC_DADIR1
47	genio47	KEY_LOCK_SWITCH
48	genio48	I2C_ISA_SDA
49	genio49	CAM_STV_LDO_EN
50	genio50	BT_HOST_WAKE_UP
51	genio51	I2C_ISA_SCL
52	genio52	POWER_SAVE_LED
53	genio53	KEYB_COLUMN_4
54	genio54	WLAN_RSTX
55	genio55	SLIDE_MR
56	genio56	SLIDE_EL_EN
57	genio57	GAMING_LED_EN
58	genio58	SD_DETECTION
59	genio59	BT_UART_IN
60	genio60	BT_UART_OUT
61	genio61	CAM_REG_EN
62	genio62	SIDE_LEDS_EN
63	genio63	KEYB_COLUMN_5
64	genio64	GAMING_KEY1
65	genio65	BT_RSTX
66	genio66	CAM_STV_PD
67	genio67	GAMING_KEY2
68	genio68	CAM_CLK
69	genio69	BT_CTS
70	genio70	BT_RTS
71	genio71	MMC_FB_CLK
72	genio72	KEYB_COLUMN_6
73	genio73	KEYB_COLUMN_7

SPECIALL_IO(7:0)

0	specialio0	CCP_DAP
1	specialio1	CCP_DAN
2	specialio2	CCP_CLKP
3	specialio3	CCP_CLKN
4	specialio4	AIC33_CLK
5	specialio5	AIC33_WCLK
6	specialio6	AIC33_DOUT
7	specialio7	AIC33_DIN

From RAPIDO sheet

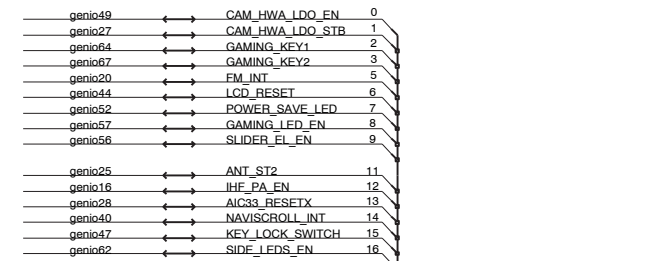
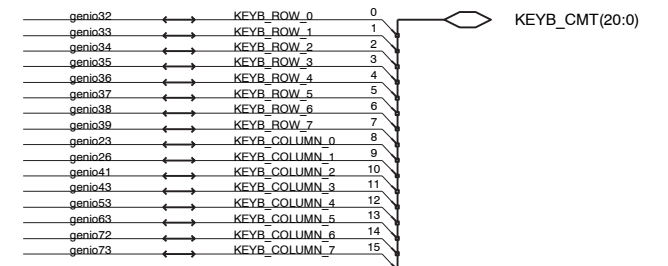
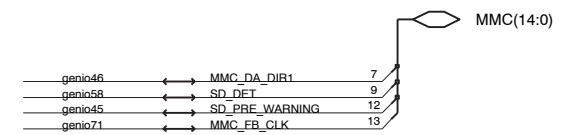
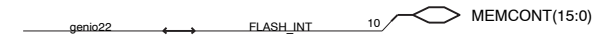
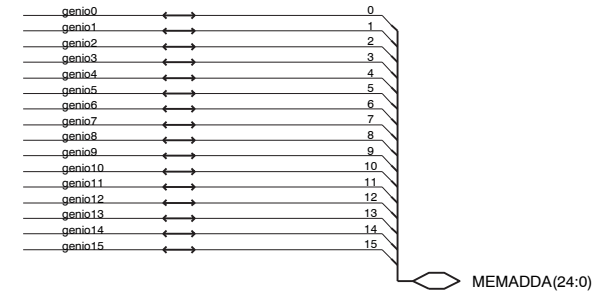
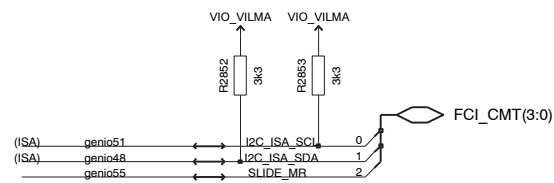
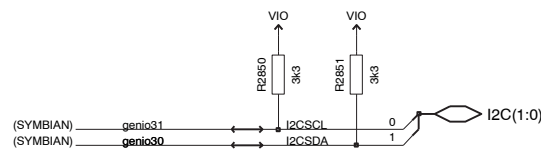
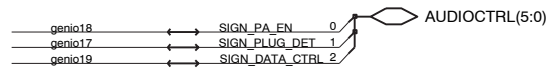
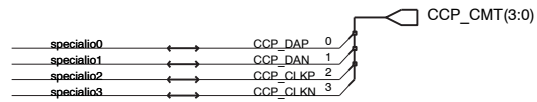
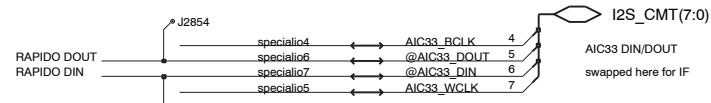
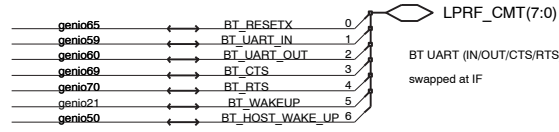
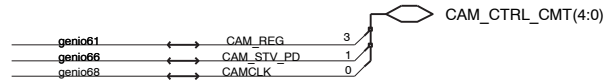
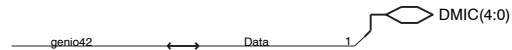
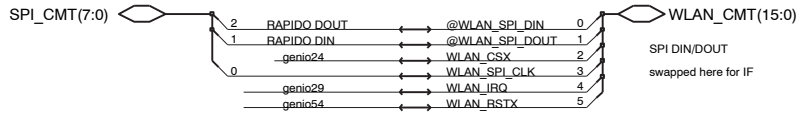

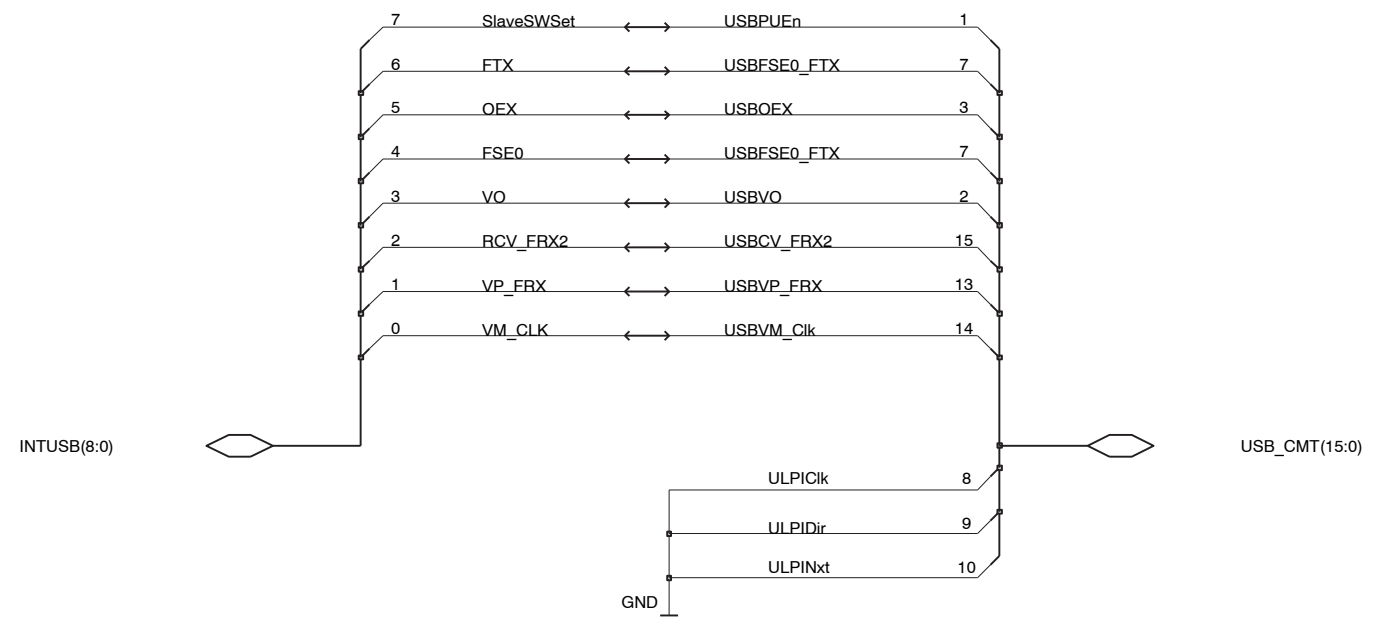

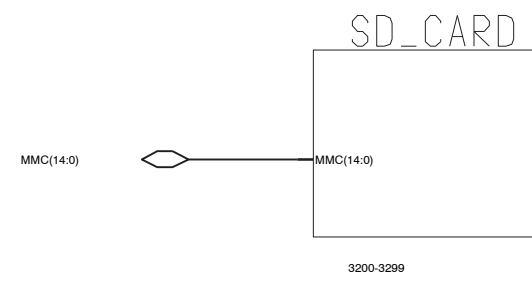
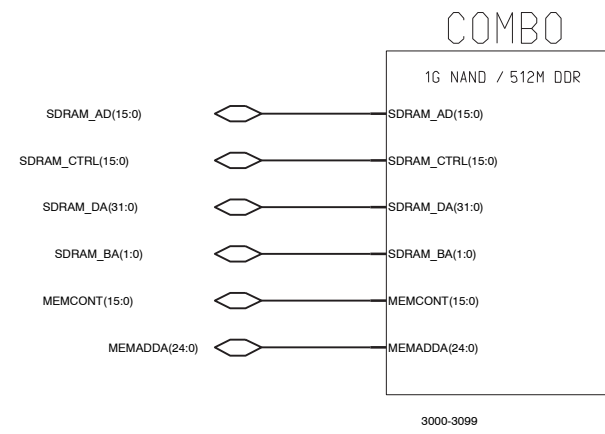

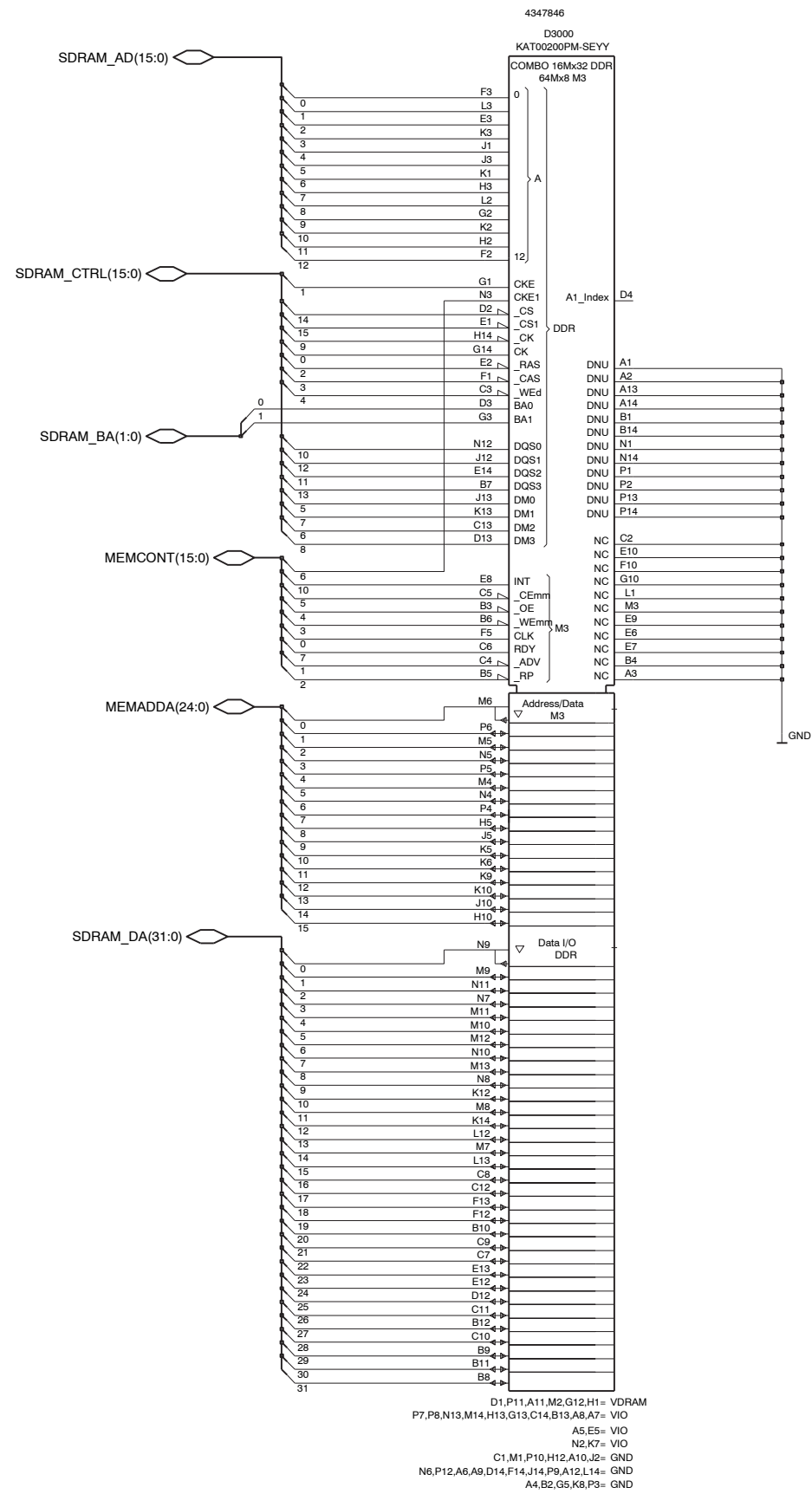
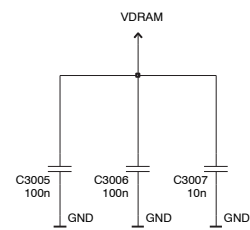
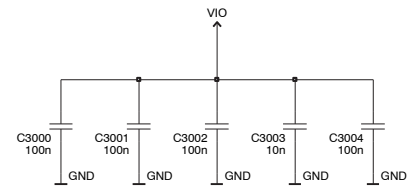

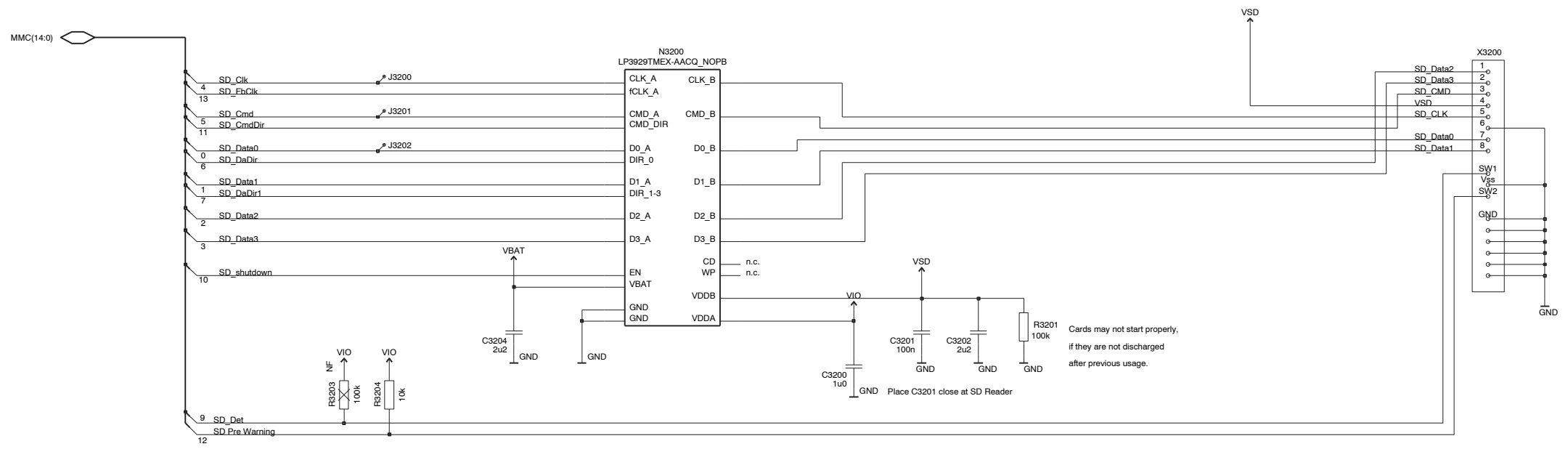

CBB5X

TOP SHEET

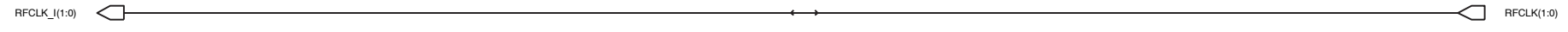

Own CLK on Wlan-sheet

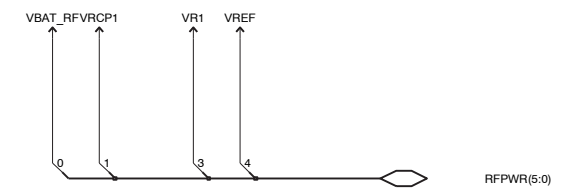
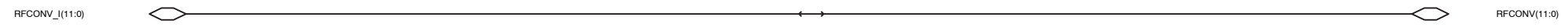

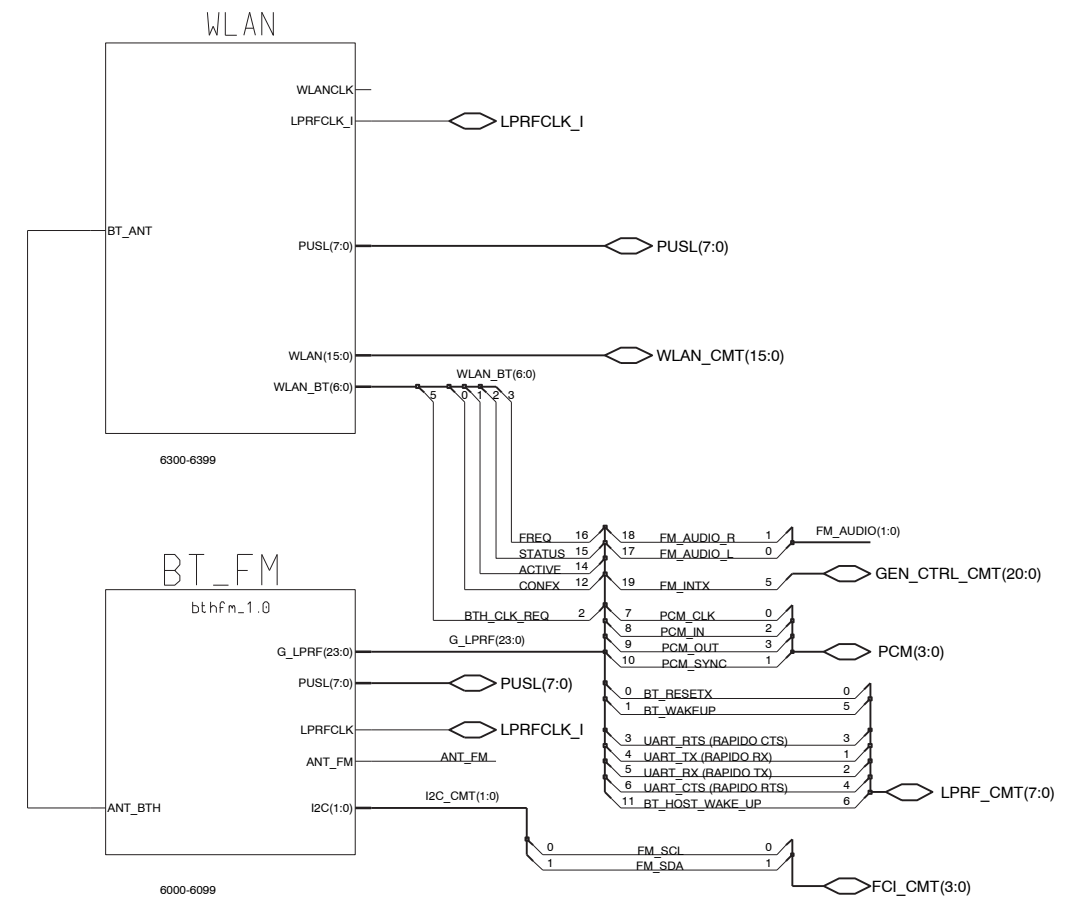
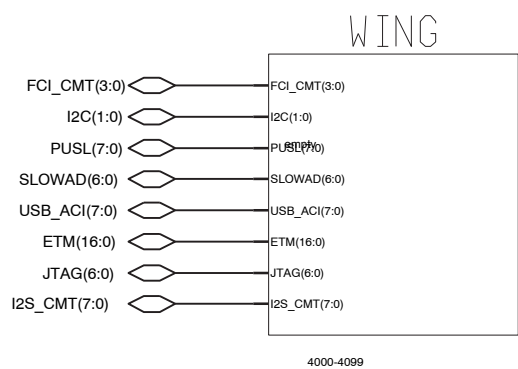
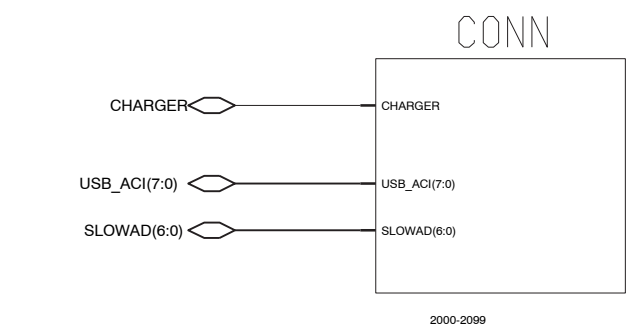
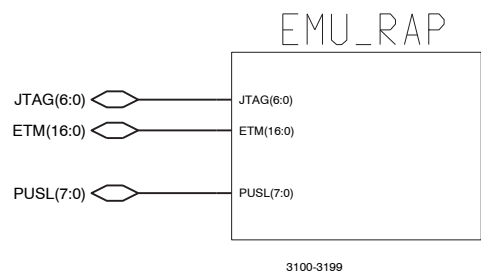
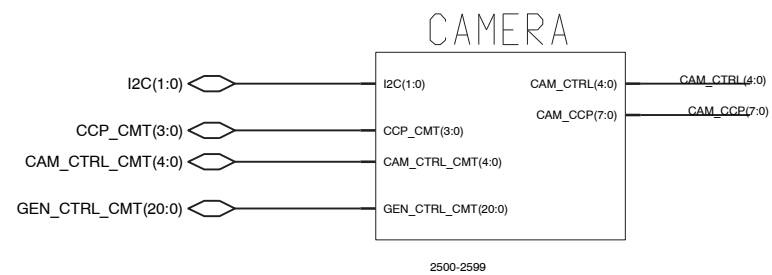
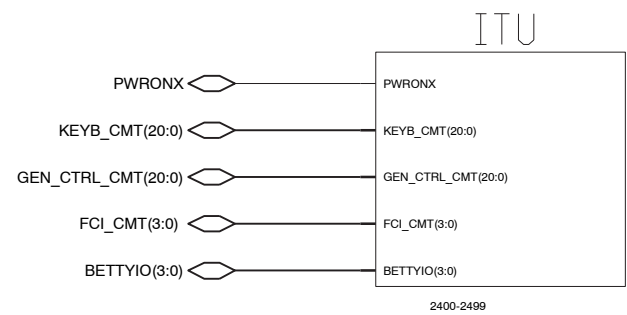
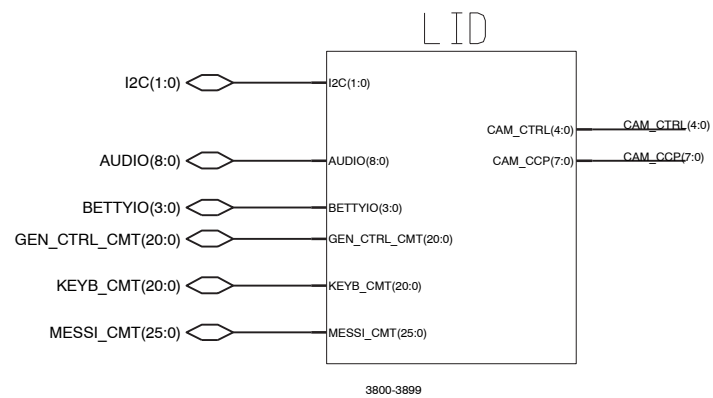
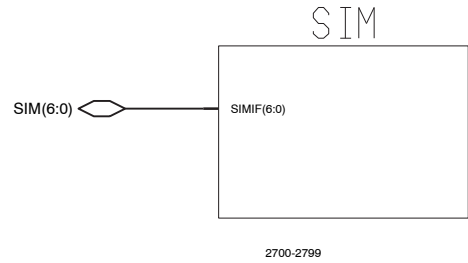
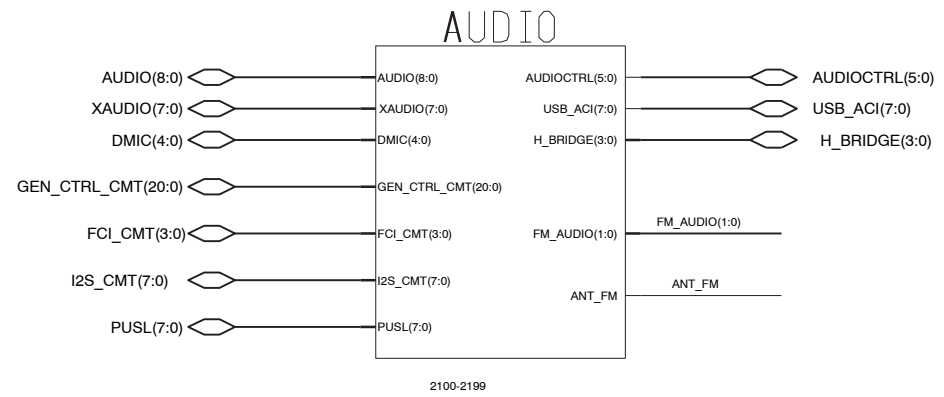

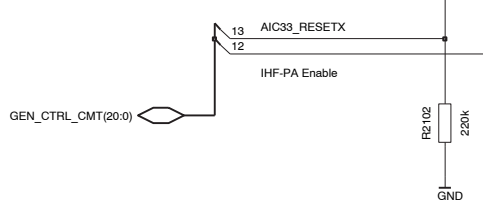
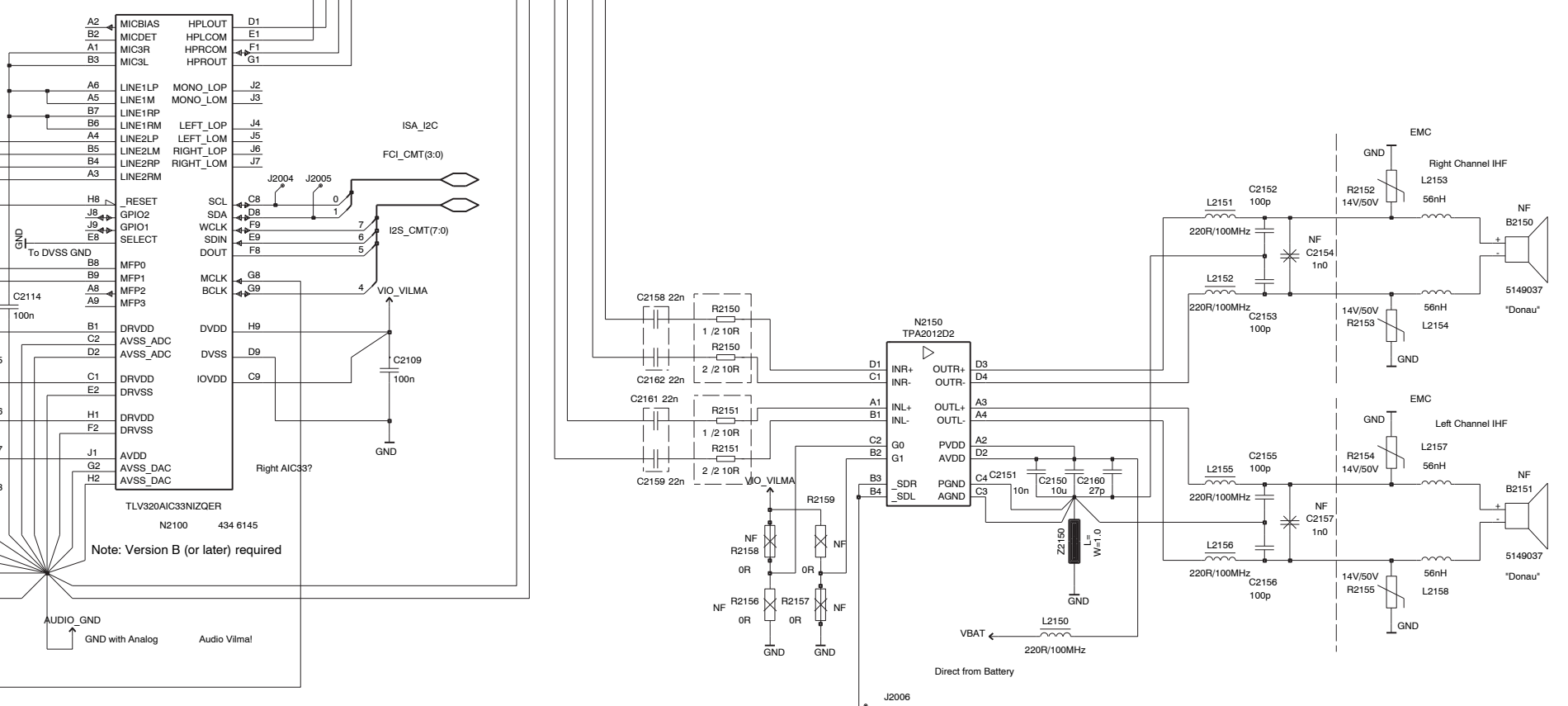
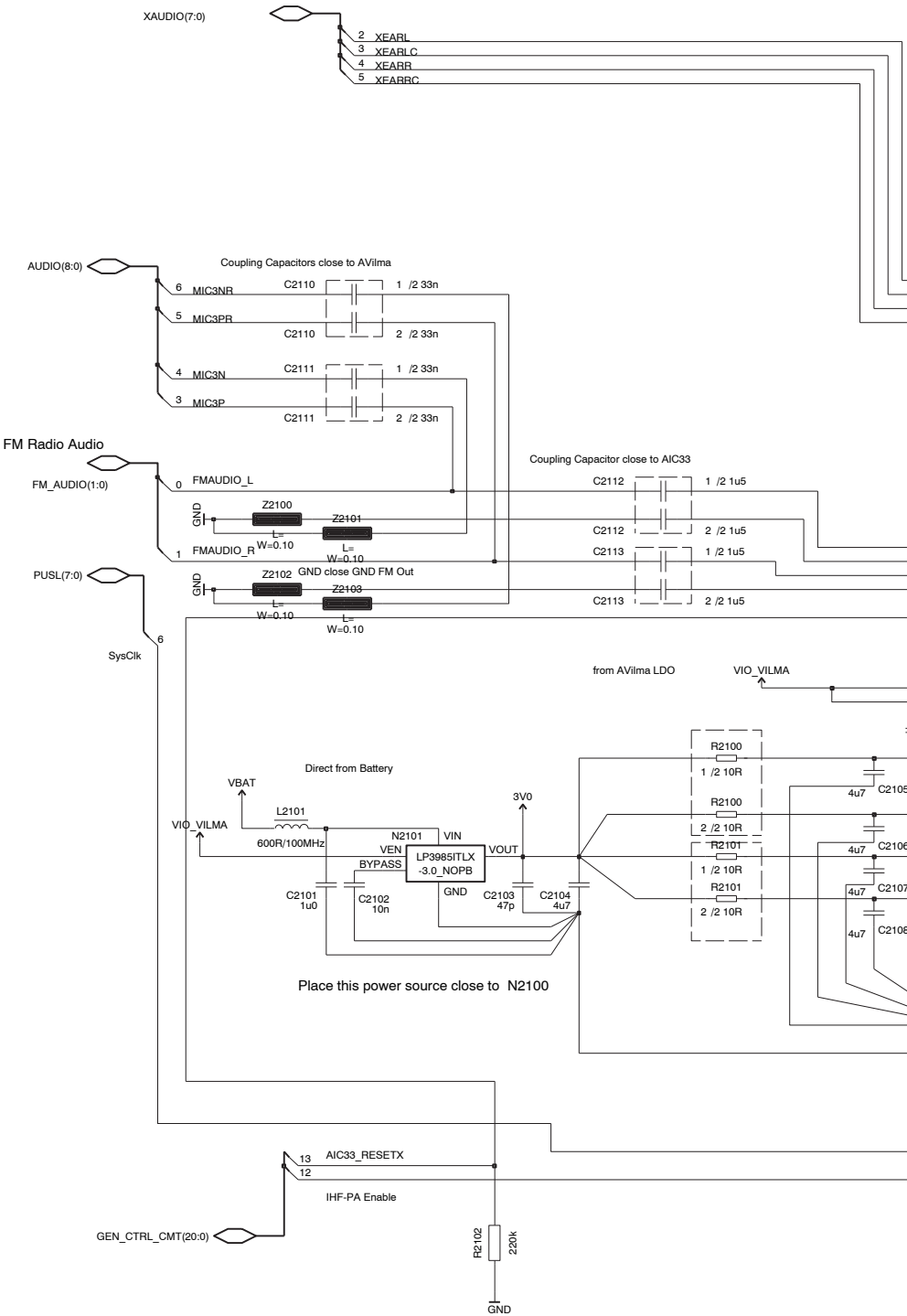
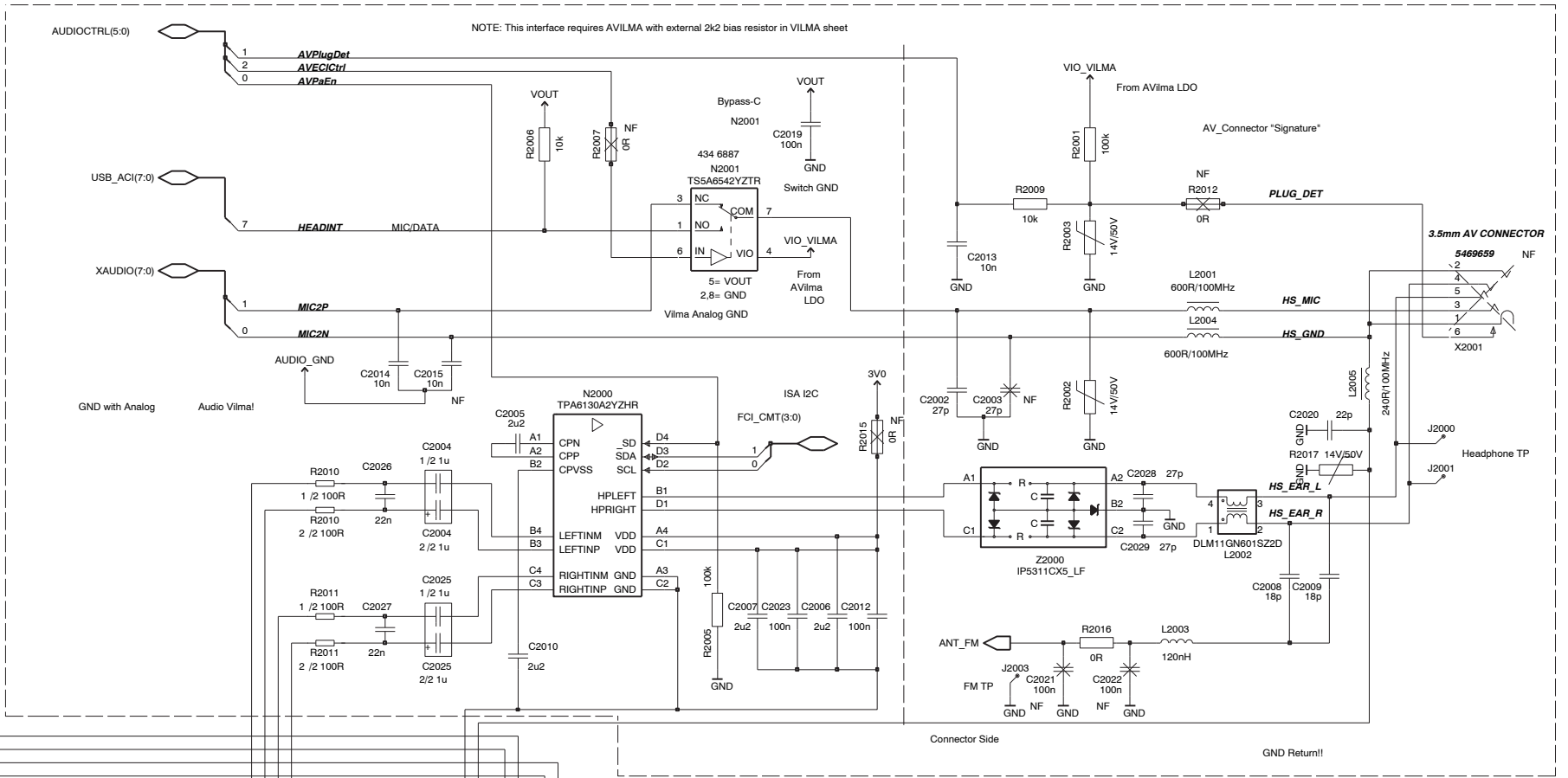
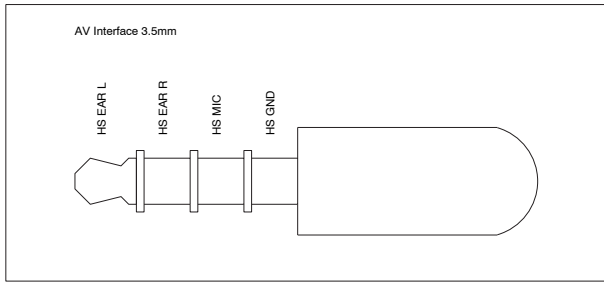

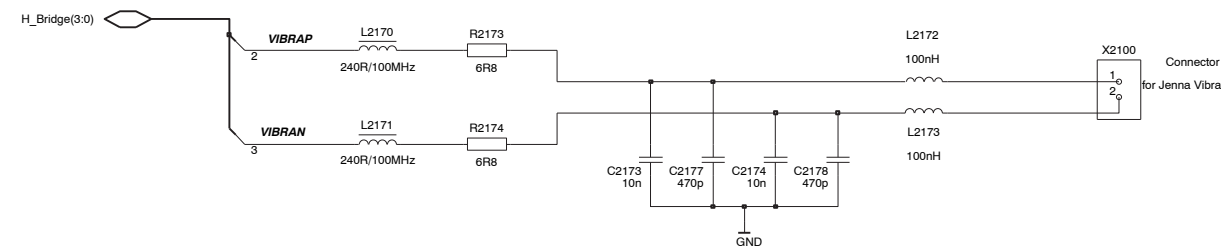
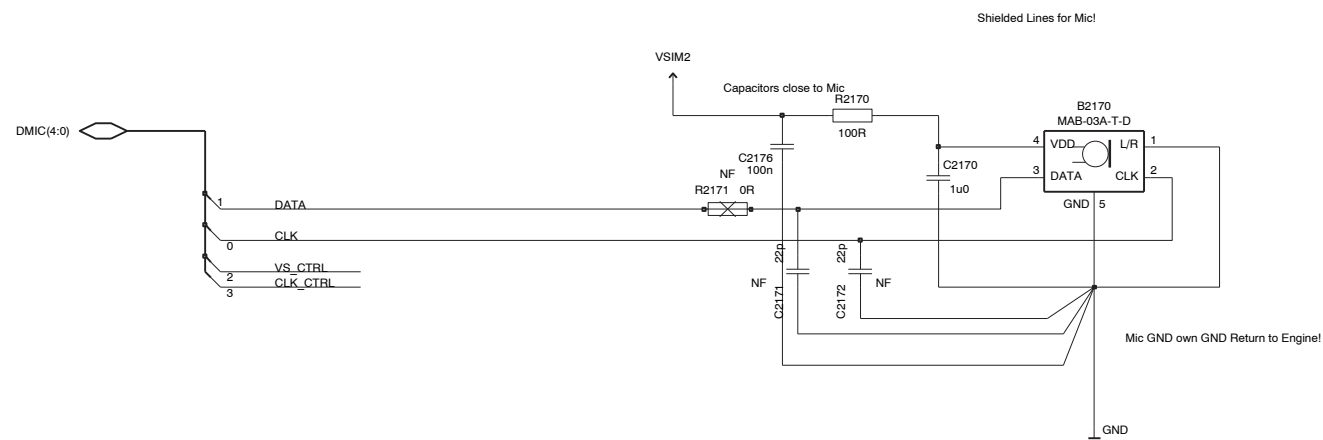

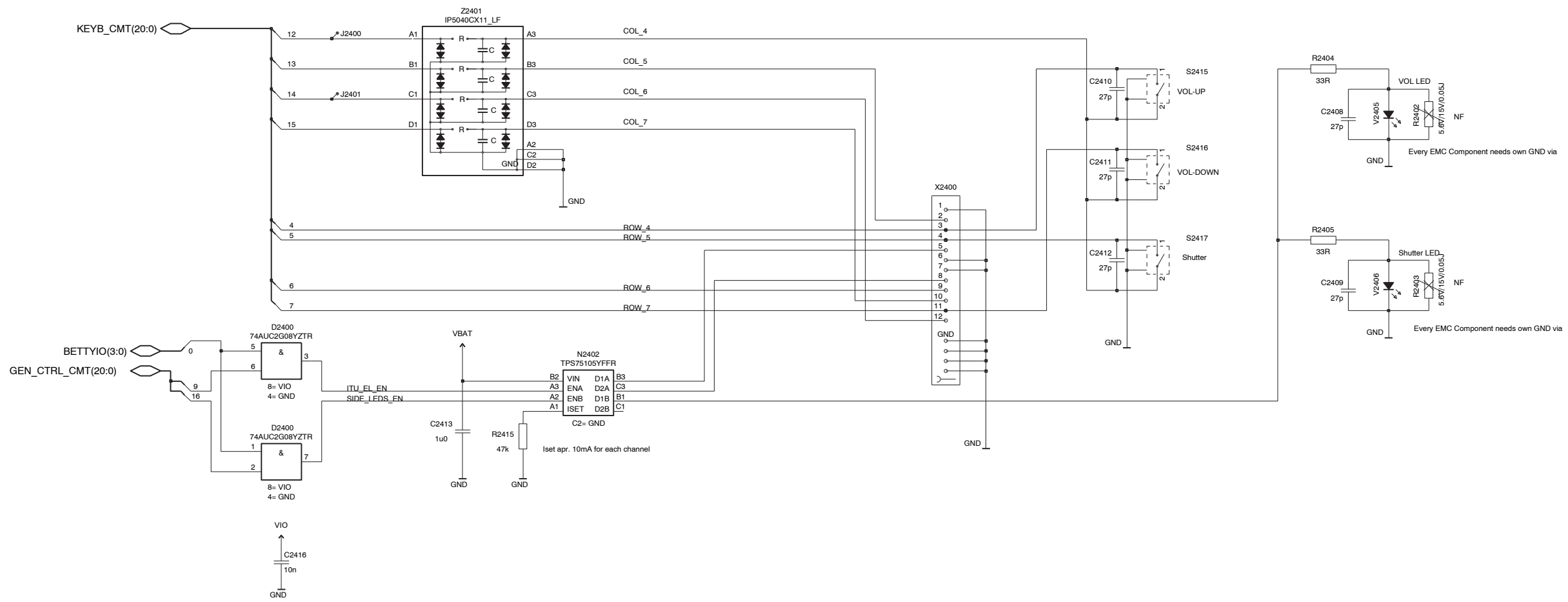
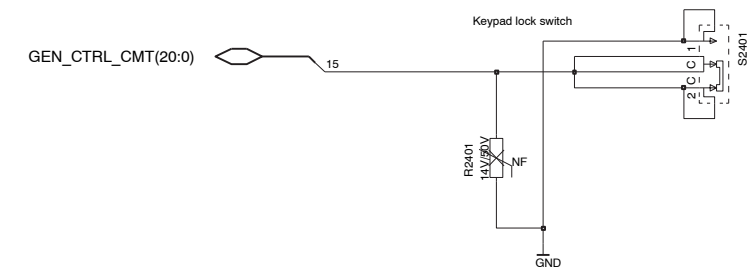
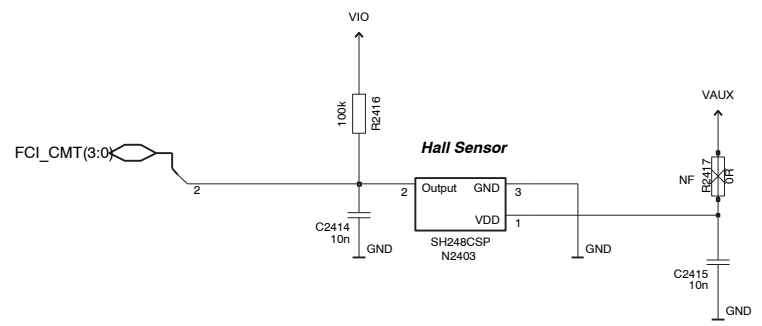
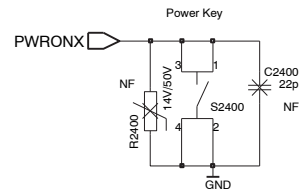

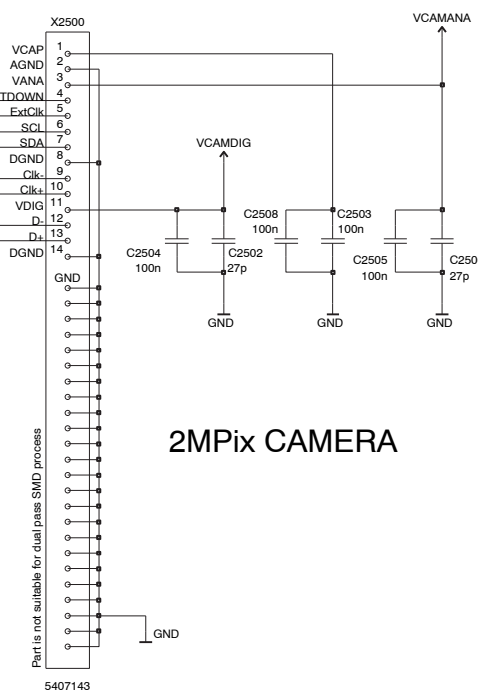
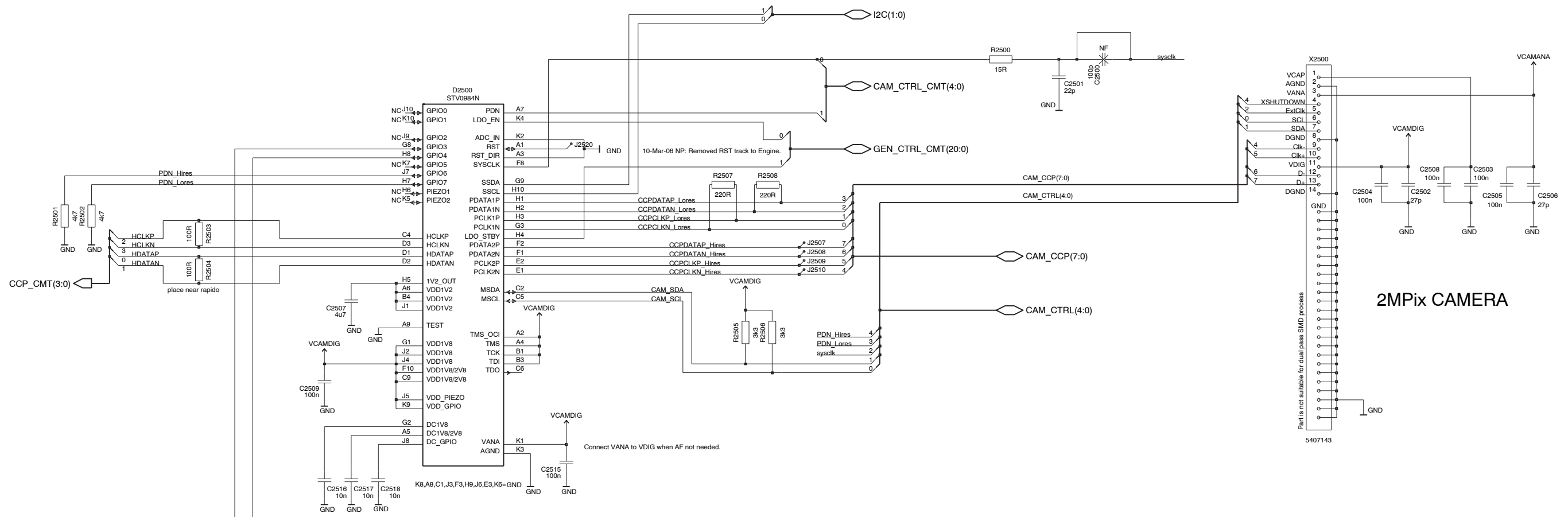

Flash LED

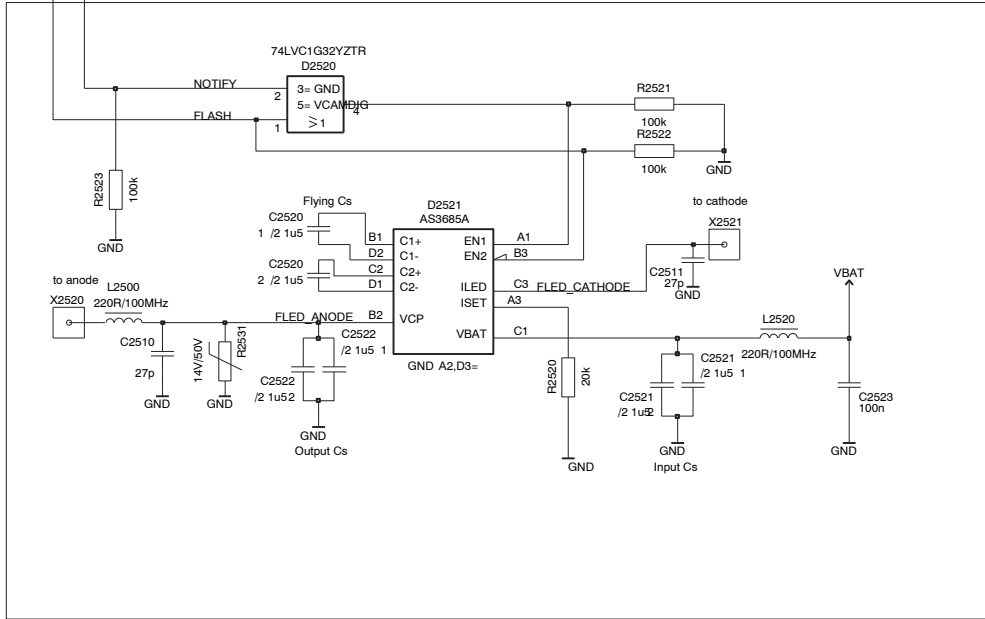

Camera Power Supply

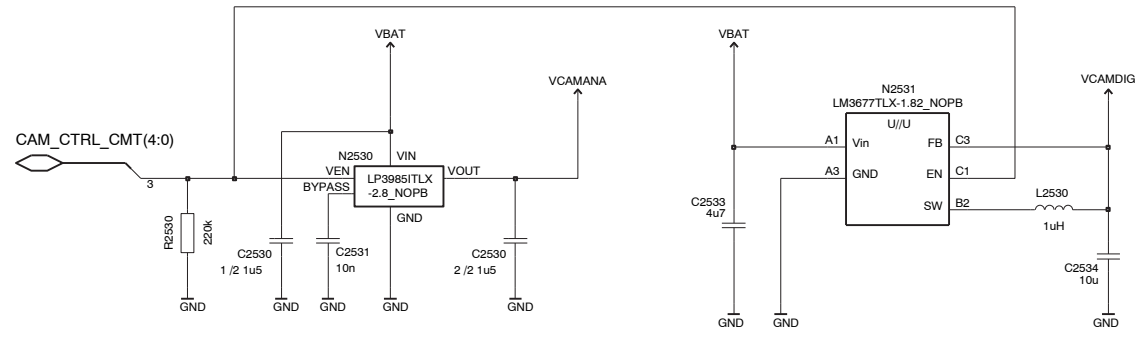

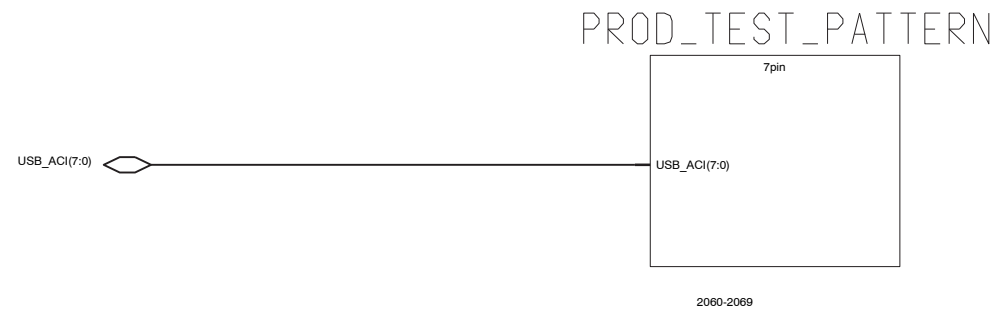
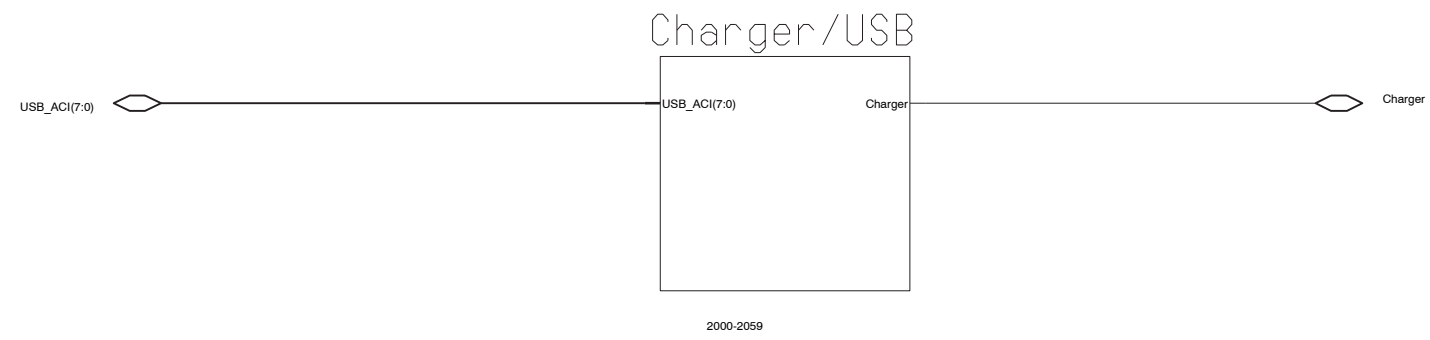

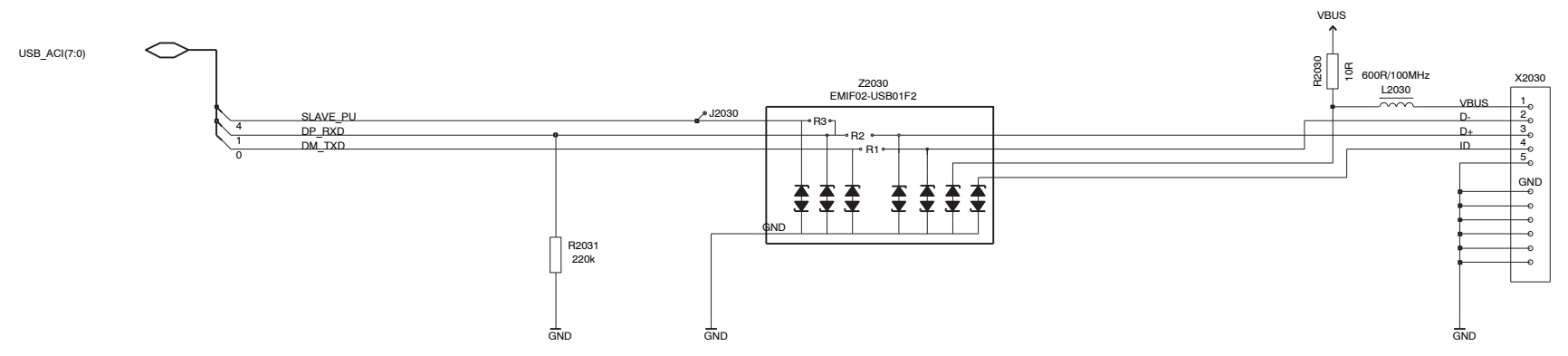
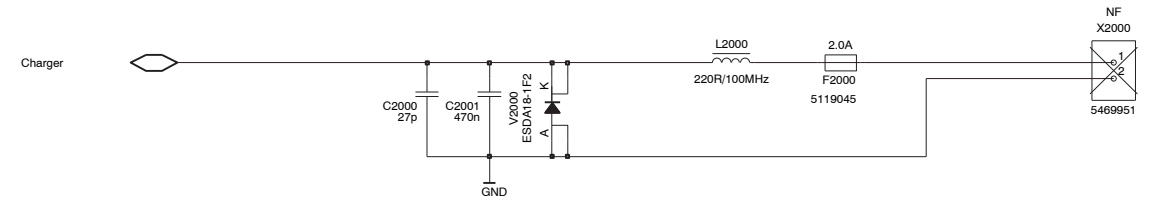

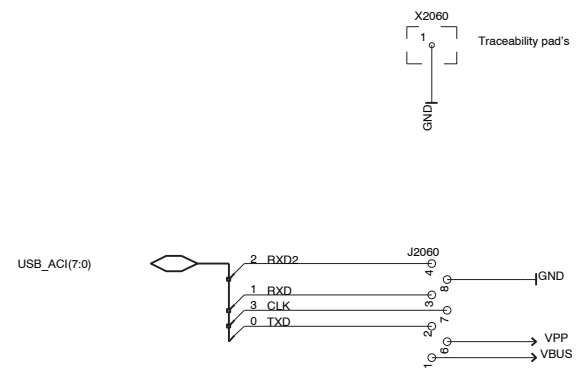

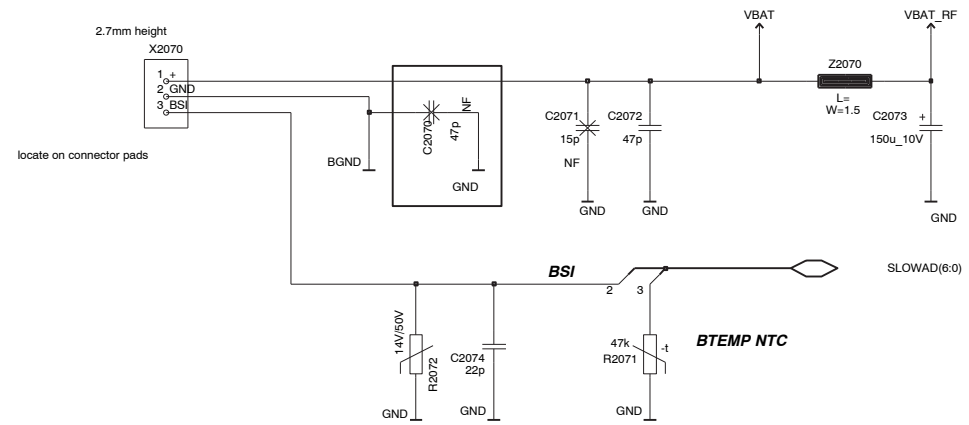

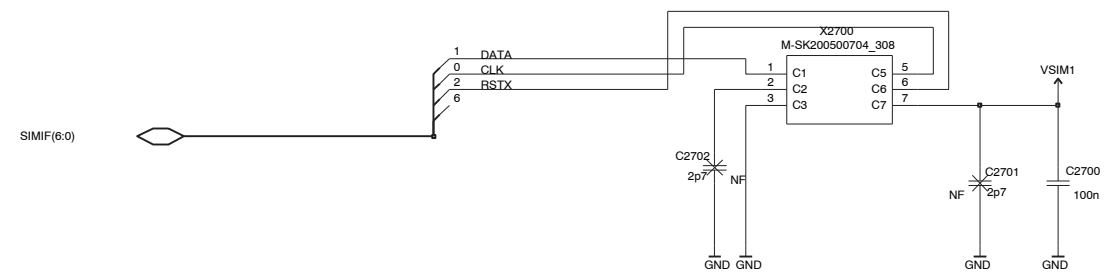

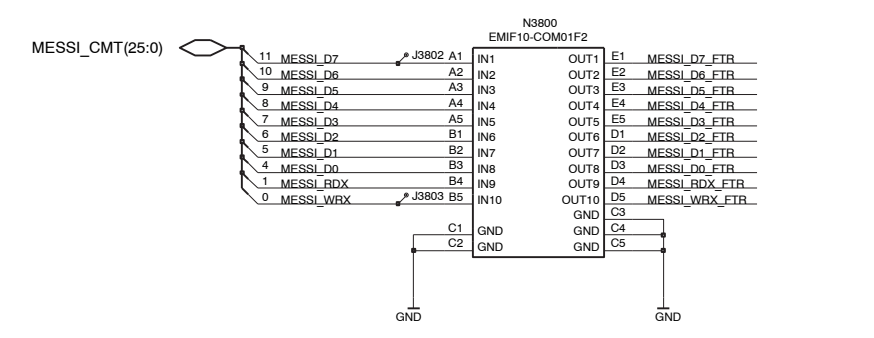
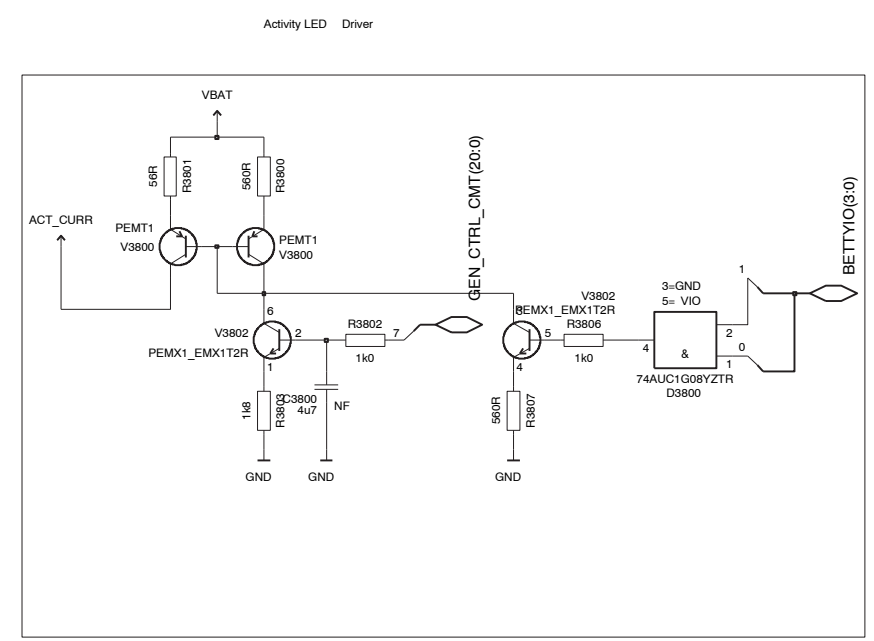
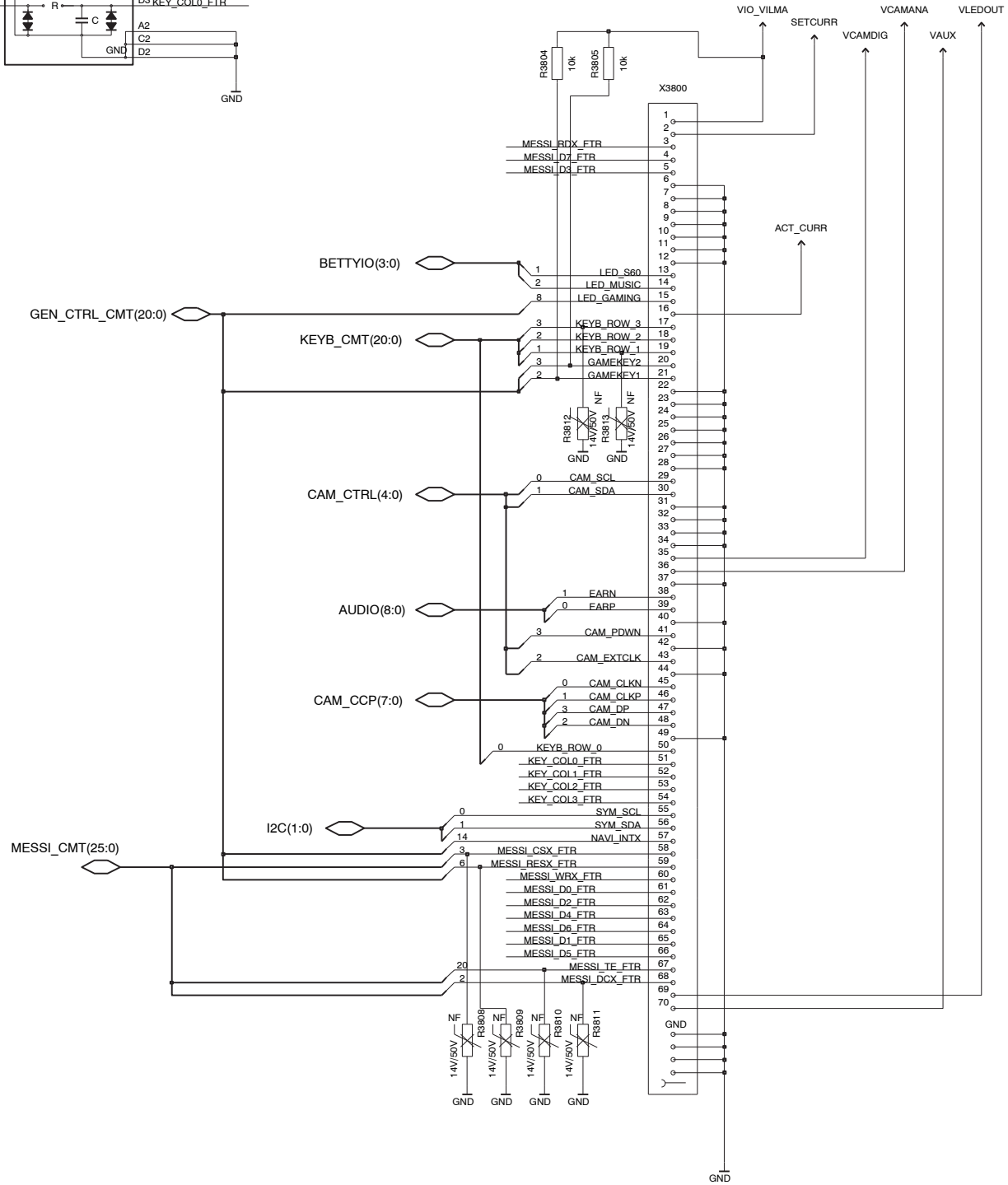
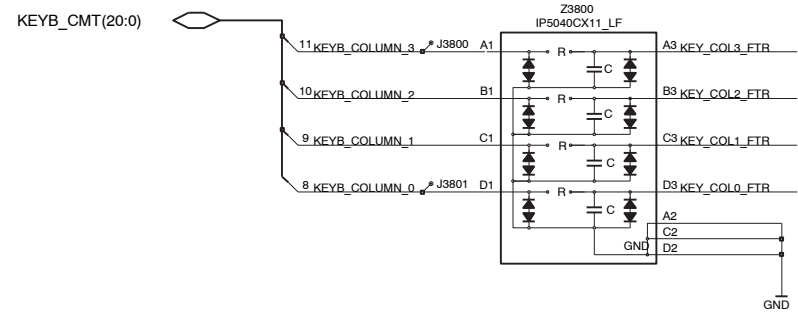

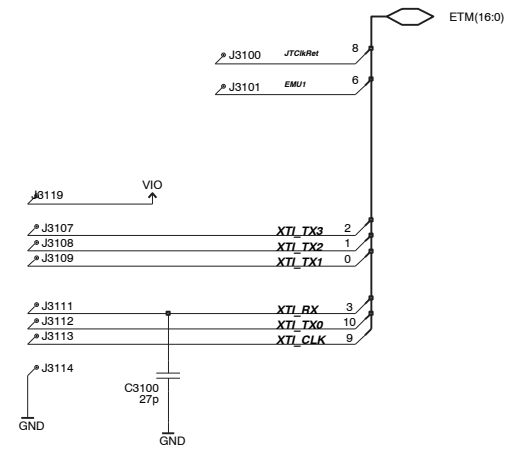
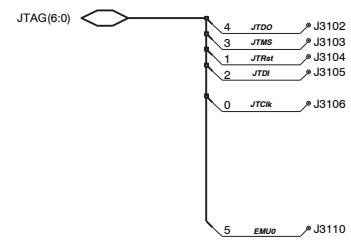

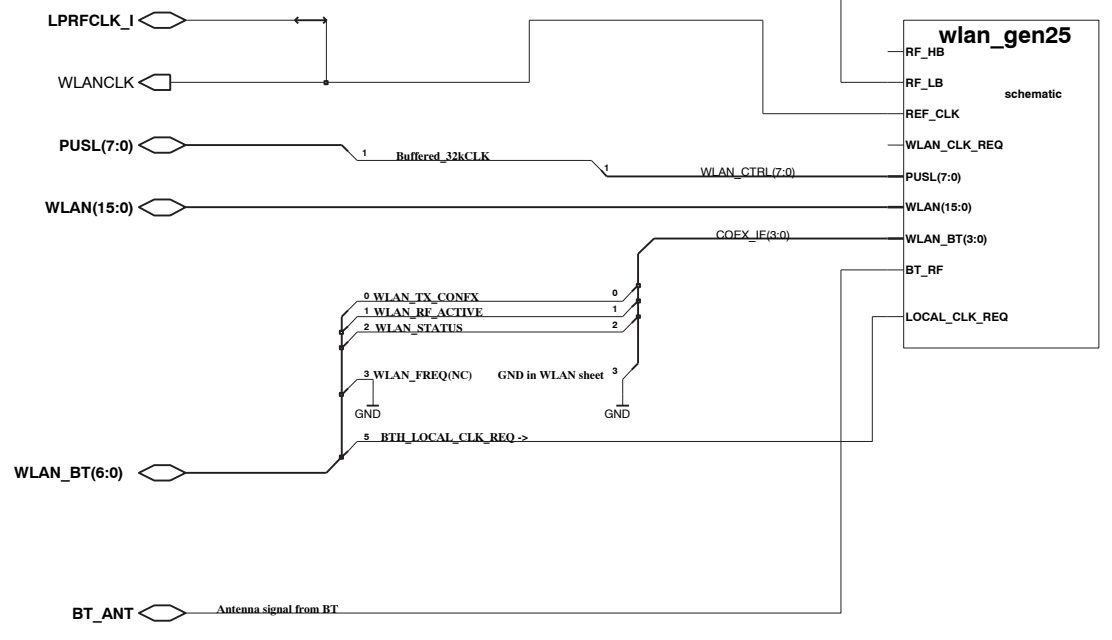
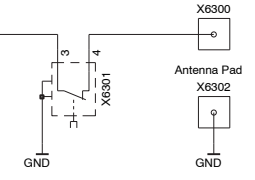
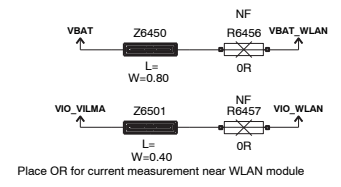

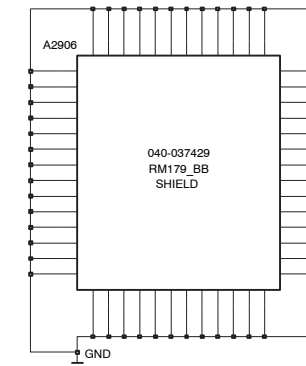
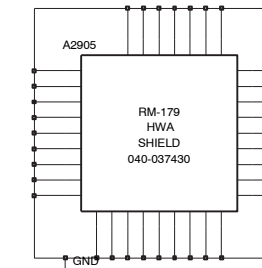
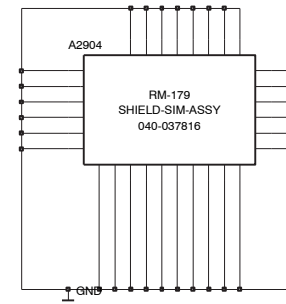
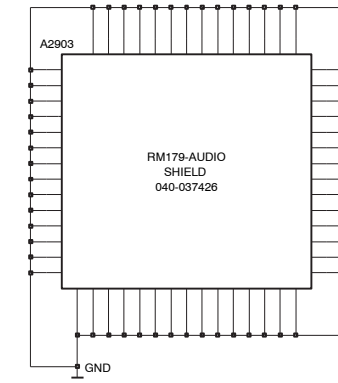
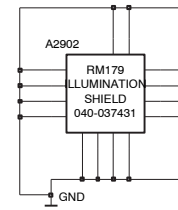
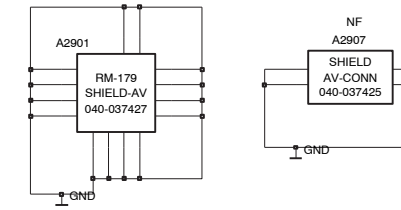
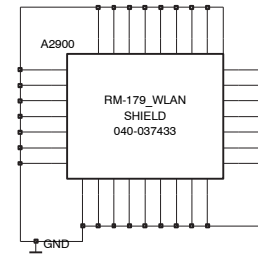

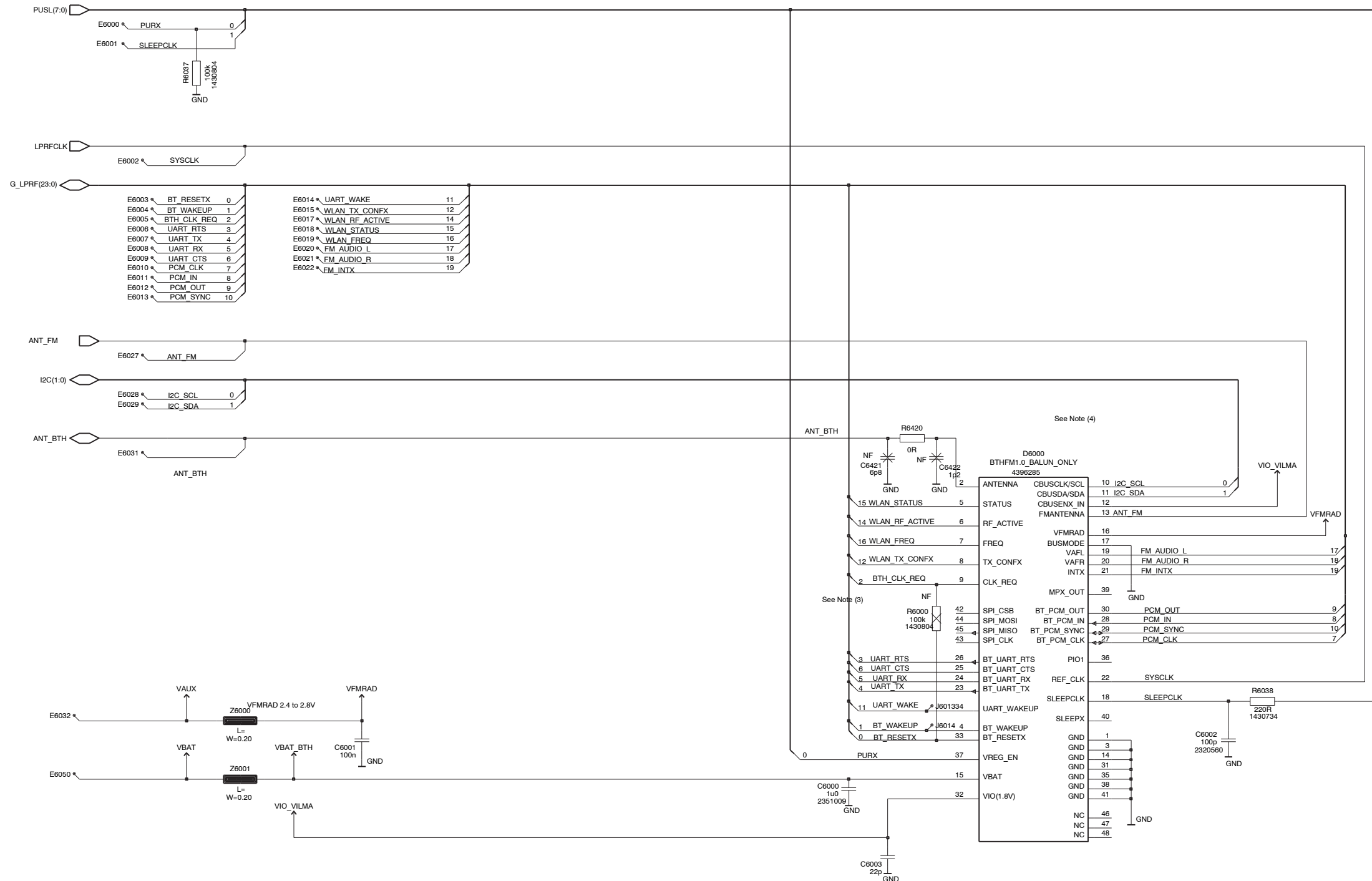

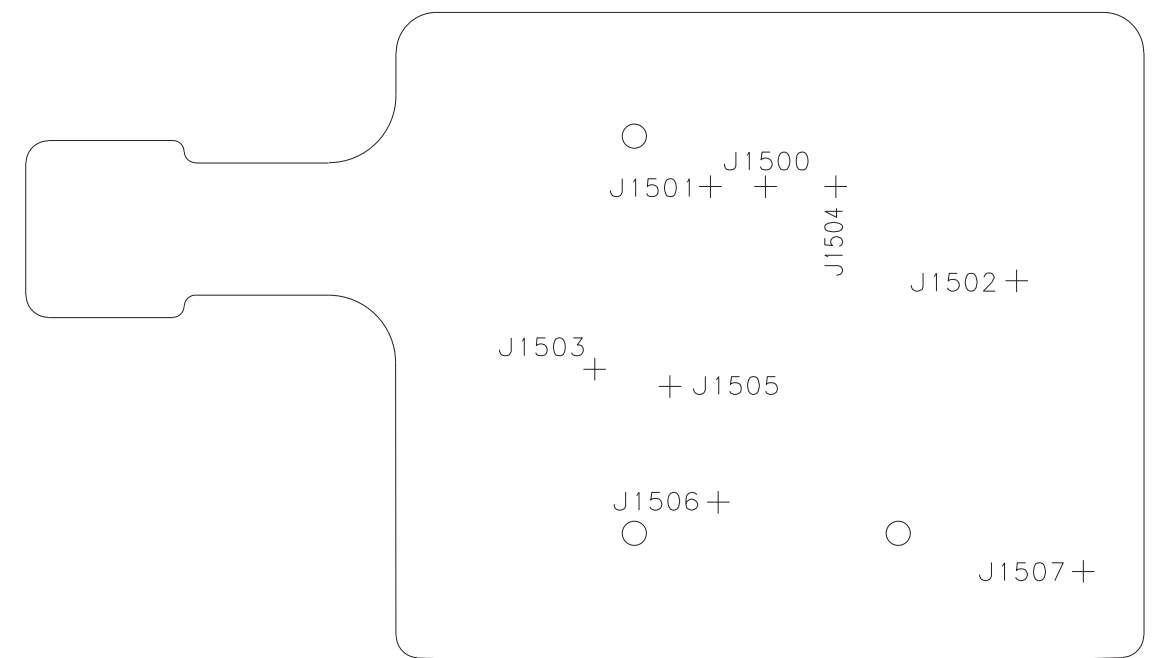
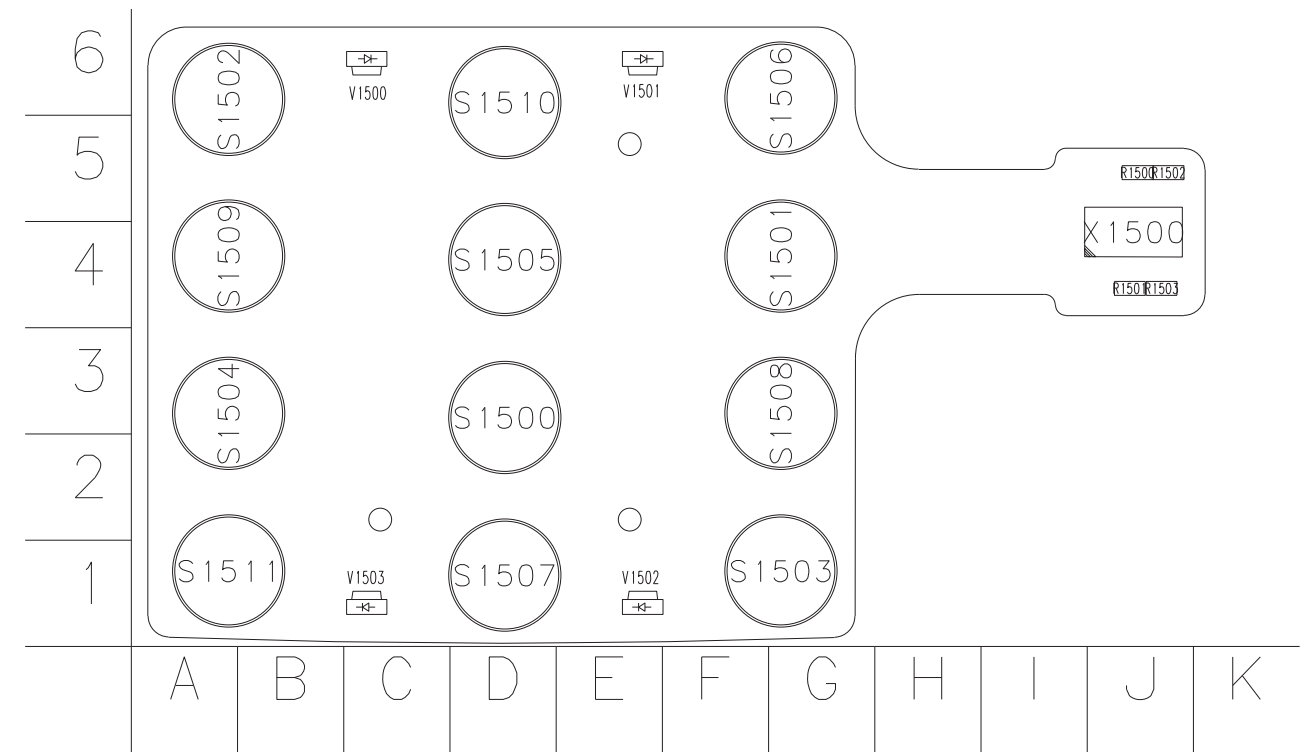
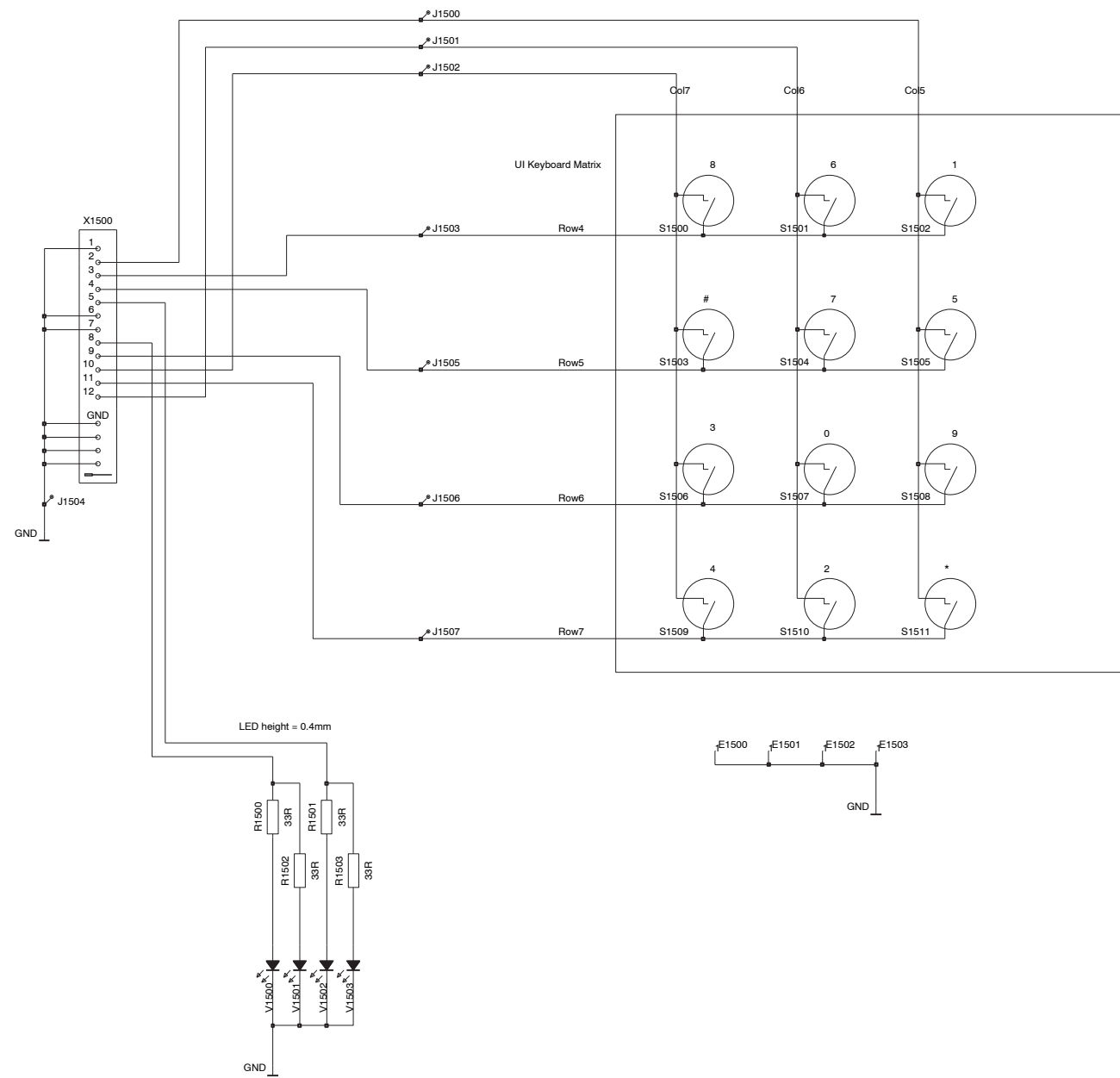

24
23
22
21
20
19
18
17
16
15
14
13
12
11
10
9
8
7
6
5
4
3
2
1

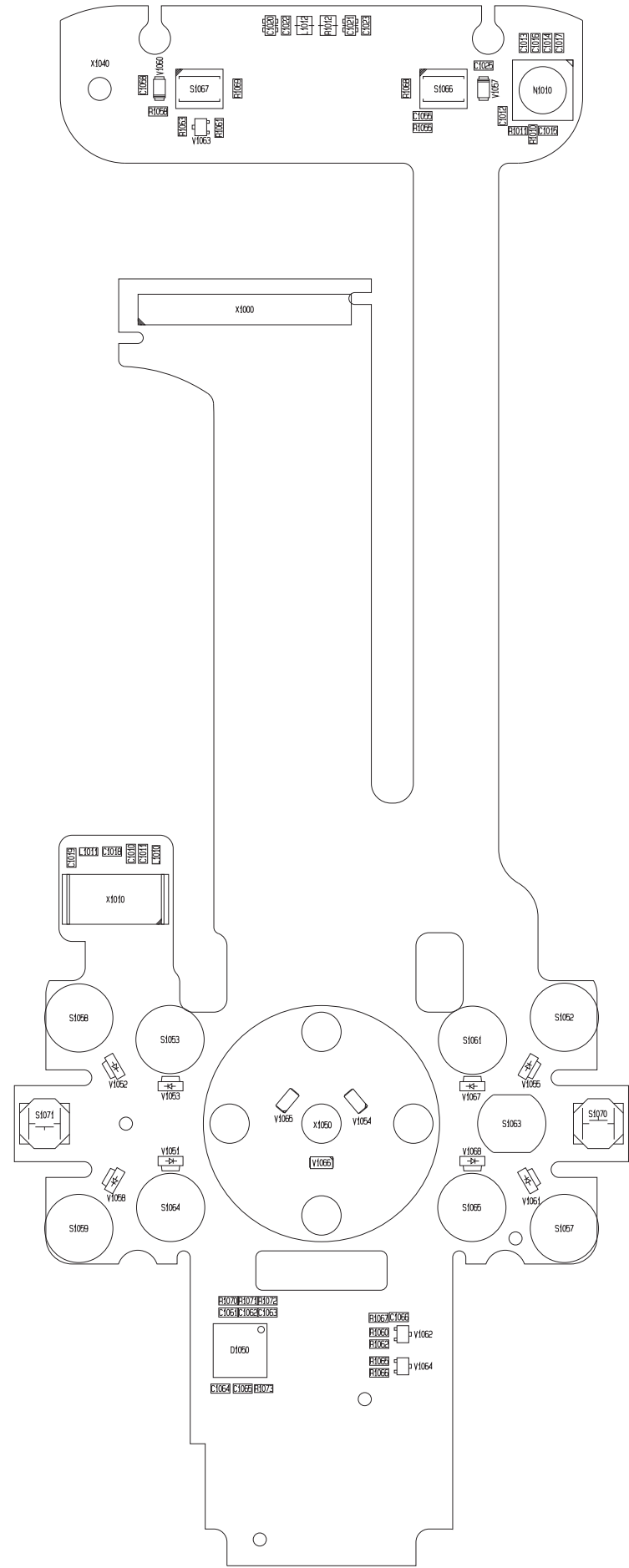

1yz_04a_asmdrw_t.pdf

A | B | C | D | E | F | G | H | I | J | K | L

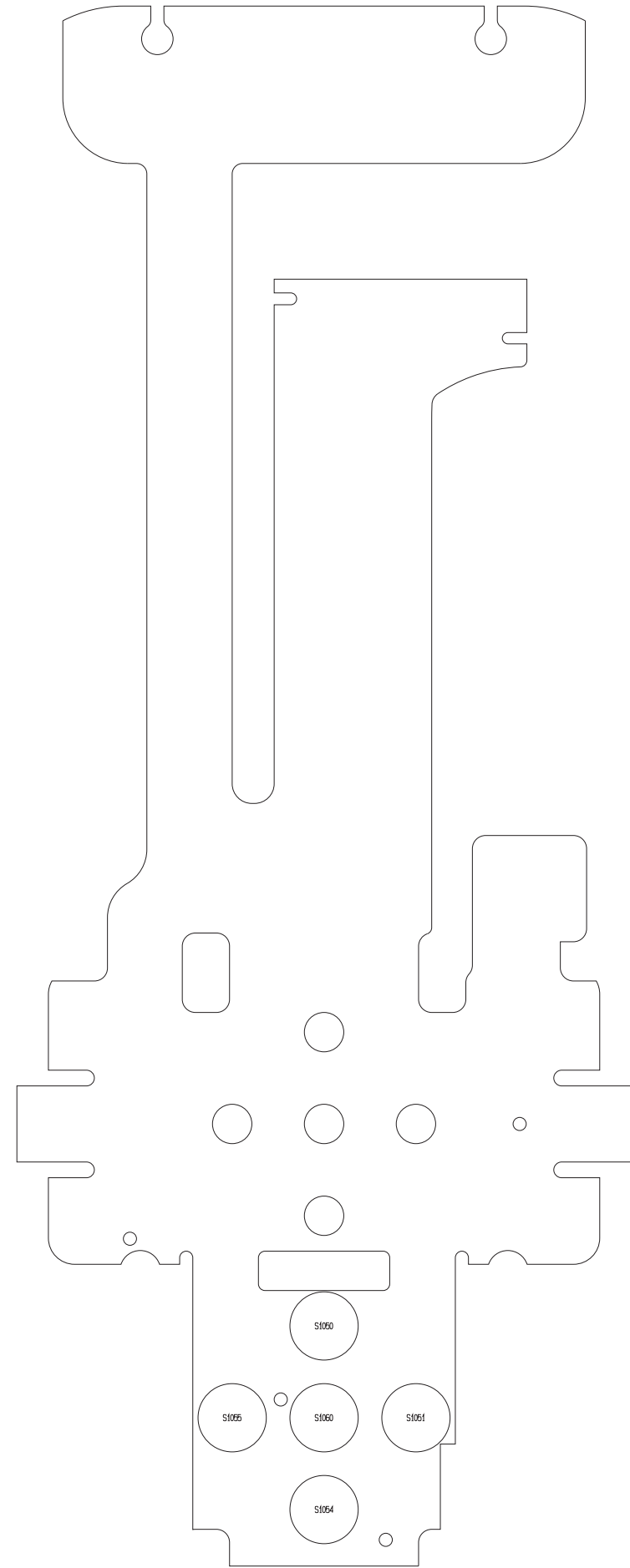

1yz_04a_asmdrw_b.pdf

L | K | J | I | H | G | F | E | D | C | B | A

24
23
22
21
20
19
18
17
16
15
14
13
12
11
10
9
8
7
6
5
4
3
2
1